

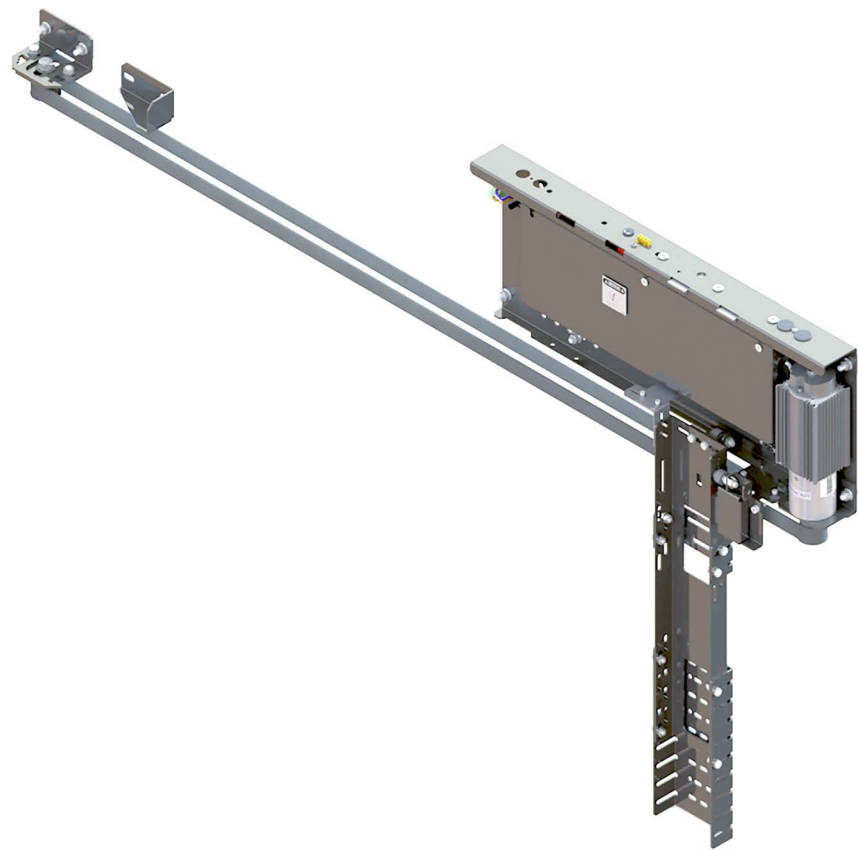

VERTICAL EXPRESS

# LD-16 Door Operator DOOR DRIVE KIT



Every attempt has been made to ensure that this documentation is as accurate and up-to-date as possible. However, Vertical Express assumes no liability for consequences, directly or indirectly, resulting from any error or omission. The material contained herein is subject to revision. Please report any problems with this manual to Vertical Express, P.O. Box 2019, Memphis, Tennessee 38101.

Vertical Express • P.O. Box 2019 • Memphis, Tennessee 38101

© 2018, 20121 Vertical Express. All rights reserved.  
Published July 2021  
First Edition  
Printed in the United States of America

**Manual Number: 88401 v.1.0**

# Contents

Safety Precautions .....	3
Terms in This Manual .....	3
General Safety .....	3
Electrical Safety .....	3
Mechanical Safety .....	4
Arrival of Equipment .....	4
Asbestos Compliance .....	4
Static Protection Guidelines .....	5
Handling .....	5
Shipping .....	5
Overview .....	7
Installation Process Overview.....	7
Required Tools and Materials .....	8
Installation .....	9
Replacement Parts .....	18
Harness Assemblies with Diagrams - COP Adapter Harnesses, 462AEM_ .....	24
Harness Assemblies with Diagrams - COP Extension Harnesses, 462AEN_ .....	29
Generic Wiring Diagrams .....	31

**This page  
intentionally  
left blank.**

# Safety Precautions

**IMPORTANT!**

Read this page before any work is performed on elevator equipment. The procedures contained in this manual are intended for the use of qualified elevator personnel. In the interest of your personal safety and the safety of others, do not attempt any procedure that you are not qualified to perform.

All procedures must be accomplished in accordance with the applicable rules in the latest edition of the National Electrical Code, the latest edition of ASME A17.1, and any governing local codes.

## Terms in This Manual

**! CAUTION**

**CAUTION** statements identify conditions that may result in damage to the equipment or other property if improper procedures are followed.

**! WARNING**

**WARNING** statements identify conditions that may result in personal injury if improper procedures are followed.

## General Safety

**! CAUTION**

Before applying power to the controller, check that all manufacturing wire connections are tight on relays, contactors, fuse blocks, resistors, and terminals on cards and DIN rail terminals. Connections loosened during shipment may cause damage or intermittent operation.

Other specific warnings and cautions are found where applicable and do not appear in this summary. See the *Employee Safety and Accident Prevention Program Manual* and the *Elevator Industry Field Employees' Safety Handbook* for electrical equipment safety information on installation and service.

## Electrical Safety

All wiring must be in accordance with the National Electrical Code and be consistent with all state and local codes.

### Use the Proper Fuse

To avoid fire hazards, use only the correct type fuse, voltage, and current rating. See the job specific drawings sheet (Power Supplies) for fusing information.

Electric shocks can cause personal injury or loss of life. Circuit breakers, switches, and fuses may not disconnect all power to the equipment. Always refer to the wiring diagrams. Whether the AC supply is grounded or not, high voltage will be present at many points.

## Electrical Safety (continued)

### Mainline Disconnect

Unless otherwise directed, always Turn OFF, Lockout, and Tagout the mainline disconnect to remove power from elevator equipment. Before proceeding, confirm that the equipment is de-energized with a volt meter. Refer to the *Employees' Safety and Accident Prevention Program Manual* for the required procedure.

### When Power Is On

To avoid personal injury, do not touch exposed electrical connections or components while power is ON.

### Test Equipment Safety

Always refer to manufacturers' instruction book for proper test equipment operation and adjustments.

Buzzer-type continuity testers can damage electronic components. Connection of devices such as voltmeters on certain low level analog circuits may degrade electronic system performance. Always use a voltmeter with a minimum impedance of 1 M Ohm/Volt. A digital voltmeter is recommended.

## Mechanical Safety

See the *Employees' Safety and Accident Prevention Program Manual* and the *Elevator Industry Field Employees' Safety Handbook* for mechanical equipment safety information on installation and service.

## Arrival of Equipment

### Receiving

Upon arrival of the equipment, inspect it for damage. Promptly report all visible damage to the carrier. All shipping damage claims must be filed with the carrier.

### Storing

During storage in a warehouse or on the job site, precautions should be taken to protect the equipment from dust, dirt, moisture, and temperature extremes.

# Static Protection Guidelines

**IMPORTANT!**

Read this page before working with electronic circuit boards.

Elevator systems use electronic circuit boards to control various functions of the elevator. These boards have components that are extremely sensitive to electrostatic voltage, which can cause board damage or failure.

Proper handling and shipping of boards is important to ensure their reliability and long-term operation. For this reason, manufacturing bases warranty decisions on the guidelines below.

## Handling

- Store all boards in separate, sealed, anti-static bags until time for installation.
- When handling boards, wear an anti-static wrist strap with ground wire. Acceptable straps are available through local electronics parts suppliers. Typical anti-static wrist straps are intended for applications below 240 VAC.
- Do not place boards on any surface without adequate static protection.
- Handle boards only by their edges using proper anti-static techniques. Avoid touching components, traces, and connectors.
- Take extra care when handling individual components, such as integrated chips, metal oxide semiconductors, and field-effect transistors. These components can be destroyed with as little as 30 volts of electrostatic discharge.

## Shipping

- Complete the included board discrepancy sheet.
- Any board returned to manufacturing must be packaged in a closed, sealed anti-static bag designed for the board, and packaged in a sturdy protective shipping carton.
- Clear bubble wrap and Styrofoam are unacceptable packing materials.



Refer to the *Replacement Parts Catalog* to order extra static bags and shipping cartons for each board.

**Failure to adhere to the above guidelines will void the card warranty.**

## Revision Change Bars

Each revised page included in this manual will have a vertical line (change bar) to the left of the text that has been added or changed. The example at the left of this paragraph shows the size and position of the revision change bar.

# Access and Egress Procedures

The access and egress procedures that are used entering the hoistway determine whether or not power is needed to perform the required task(s). If not, Turn OFF, Lockout, and Tagout the mainline disconnect.

## Car Top Safety

**! WARNING** DO NOT stand on the car top emergency access cover.

### Safety Precautions When Accessing/Egressing Car Tops

- Before opening the hoistway door, ensure that the correct hoistway has been selected and that the car is at the proper floor (to avoid a fall hazard).
- Access car tops from the top terminal landing whenever possible.
- Never access a hoistway, unless a reliable method of controlling the car has been determined.
- Locate the emergency stop switch.
- Before accessing the car top, place the stop switch in the STOP position, and confirm the proper operation.
- Locate a safe refuge area.
- Always maintain control of the hoistways doors during access/egress.
- Use fall protection when a fall hazard exists. The only exception to this is when routine maintenance is being performed on top of complete, operational elevator cars. Do not use fall protection where there is a greater risk of entanglement.
- When opening hoistway doors from the car top, do so slowly, so that no one steps in from the landing thinking a car has arrived.
- Observe overhead clearances.
- Use extra care when working on car tops that are curved, domed, or located in unenclosed hoistways.

**! WARNING** DO NOT turn the following switches to Automatic Operation until the hoistway door interlock is open—and remains open—and the hoistway is empty.

- When egressing the hoistway/car top, ensure that the stop switch is in the STOP position, and that the inspection switch is on Inspection Operation.

### Safety Precautions When Working on Car Tops

**! CAUTION** DO NOT attach electrical cords on the car or counterweight ropes.

- Before beginning work, check car top for oil or grease, and clean as required.
- Locate the position and counterweights of the car being accessed as well as any other cars/counterweights in the vicinity. Take appropriate measures to avoid hazards.
- Verify proper operation of the top-of-car inspection operating buttons. Where outlets are provided, use a grounded, portable light with a suitable, non-conductive; or use a grounded lamp guard and reflector.



## Access and Egress Procedures

*(continued)*

### Pit Safety

Before entering a pit, ensure that every employee is aware of the hazards. Some common hazards are:

- Recognized refuge space
- Inadequate lighting
- Improper access
- Tripping hazards
- Improper use of pit ladders
- Moisture/water/fluid
- Moving equipment

### Safety Precautions Before Entering a Pit

Take appropriate steps to minimize the following hazards and any others that are identified, such as:

- Locate the position of the car being accessed, as well as any other cars in the vicinity.
- Before accessing the pit, the car **MUST** be located high enough to allow the placement of the pit prop pipe stands to be inserted into the buffers.
- Once the pit is initially accessed, the pit props must be installed and the oil line shutoff valve closed to prevent car movement.
- Obtain control of the car.
- Identify a refuge space.
- If movement of the elevator is not needed to complete the work being performed, Turn OFF, Lockout, and Tagout procedures are required.
- If notified by the building owner or representative that the pit and/or hoistway has been classified as a Permit Required Confined Space (this notification could be verbal or the pit/hoistway may be labeled), contact the appropriate person for authorization. In either case, do not enter the pit/hoistway until authorization is received.

### Safety Precautions When Working In Pits

- Before entering a pit, test and verify the door lock circuit and stop switch circuit.
- Ensure that all portable lights and tools are connected through a ground fault (GFCI).
- Take care to protect all lighting from damage.
- **DO NOT** work in a pit with standing water.
- Before climbing, always examine shoes for fluid/grease.
- Use both hands when working with ladders and also when accessing and egressing a pit.
- Be aware of moving equipment (e.g., pump, motors, belts, and sheaves), and ensure that clothing and hands cannot get caught in them.
- Avoid smoking or the use of open flames in the pit.



**This page  
intentionally  
left blank.**

# Overview

- The LD-16 Door Operator Door Drive Kit is designed to replace an existing door operator.
- The installed door panels, door tracks, hangers, rollers, relating cables, and clutch are reused.
- Relating cable kits are available for GAL and Dover center-opening doors.
- For handed doors, the kit is ambidextrous and the opening hand may be switched during installation, if required.

## Installation Process Overview

1. Locate the new door operator position - measure the existing clutch face to the opening.
2. Remove the existing door operator machine, the drive arms, the clutch rods, and the door operator wiring harness—Keep the car door clutch and all other removed components until the elevator is running.
3. Alter the existing header to allow for proper front-to-back and side-to-side placement of the Door Drive Kit.
4. Mount the Door Drive Kit (door operator, drive unit, and belt system).
5. Install the new wiring harness, routed to the COP.
6. Install the new relating cable assembly, if provided.
7. Install the clutch linkage/clutch rod.
8. Mechanically adjust the door operator to obtain smooth mechanical door movement.
9. Electrically adjust the door operator to verify that the controls interface functions properly (movement commands, limit outputs, etc).
10. Test operation at each floor and verify the following: proper door cycling and operation, nudging speed, door torque, and kinetic energy.
11. Return the car to service.

# Required Tools and Materials

- Ratchet wrenches: 13 mm, 17 mm,  $\frac{1}{16}$ " ,  $\frac{3}{4}$ "
- $\frac{3}{8}$ " ratchet & extension
- Sockets: 13 mm, 14 mm, 15 mm,  $\frac{1}{64}$ " ,  $\frac{3}{4}$ "
- T-handle (Allen keys): 4 mm, 5 mm, 6 mm,  $\frac{3}{16}$ "
- $\frac{3}{8}$ " socketed-head Allen key
- Flat & Phillips screwdrivers
- Torpedo or tool box level
- Tape measure or folding ruler
- Door pressure gauge
- $\frac{1}{4}$ " cordless impact with 12" extension
- Sawsall with metal cutting blades (MOD applications)
- Pallet jack
- Hand trucks
- Tin snips
- Pry bar
- Claw hammer
- Tri square
- Small plumb bob
- Large channel locks
- $\frac{5}{16}$ " nut driver for impact
- $\frac{3}{8}$ " impact gun adapter
- Wire strippers
- Scribe
- Electrical tape
- Small straight slot screwdriver (plug wiring)
- Runbug
- Grinder
- Hack saw

# Installation



Most Modernization jobs are unique; adjust the following procedures to the job site.

1. Remove the existing door operator drive components, and keep all removed parts until the elevator is running. See Figure 1.
2. If needed, remove part of the header (for clearance of the mounting angles) so that it is even with the top of the header.

## IMPORTANT!

Keep the following items to reuse later in this installation:

- Existing tracks
- Hangers
- Door rollers
- Door hangers
- Door relating cables
- Door restrictors
- Clutch



Figure 1 - Existing Door Operator Drive Components Removed Installation

3. Install the drive controller.
  - a. Use the included hardware to attach the support angles to the existing door operator header. See Figure 2 below and Figure on page 11.
  - b. Install the door operator controller onto the unistrut. For easy access onto the car top, install the short unistrut at the top of the door operator and the long unistrut at the bottom of the operator.
  - c. Bolt the third support angle to the original door operator header bracket.



For adjustment in/out: use the car door drive arm (once installed) to plumb the door operator.



Support angles are mounted to the strut, and installed against the car header.

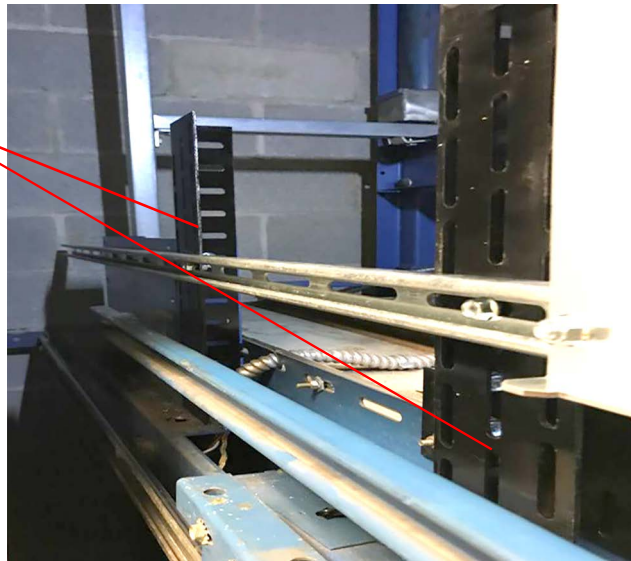

Figure 2 - Install Support Angles

Installation  
(continued)

Support Angles  
Measurement

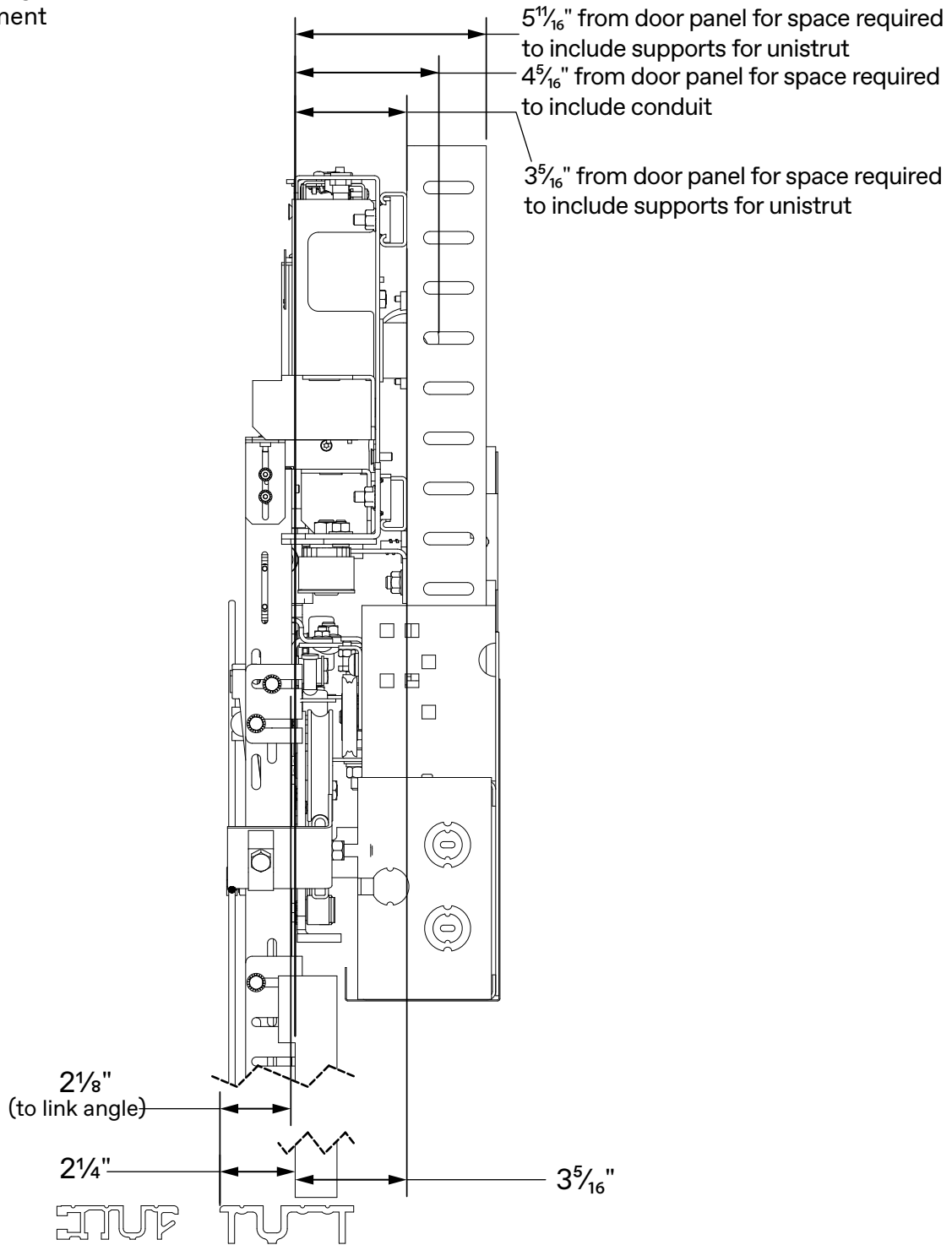

Figure 3 - Support Angles Measurement Reference

Installation  
(continued)

4. Verify that the door operator drive pulley will clear the car header or unistrut by a minimum of 1/2". To adjust, raise or lower the unistrut on the vertical support angles. See Figure 4.

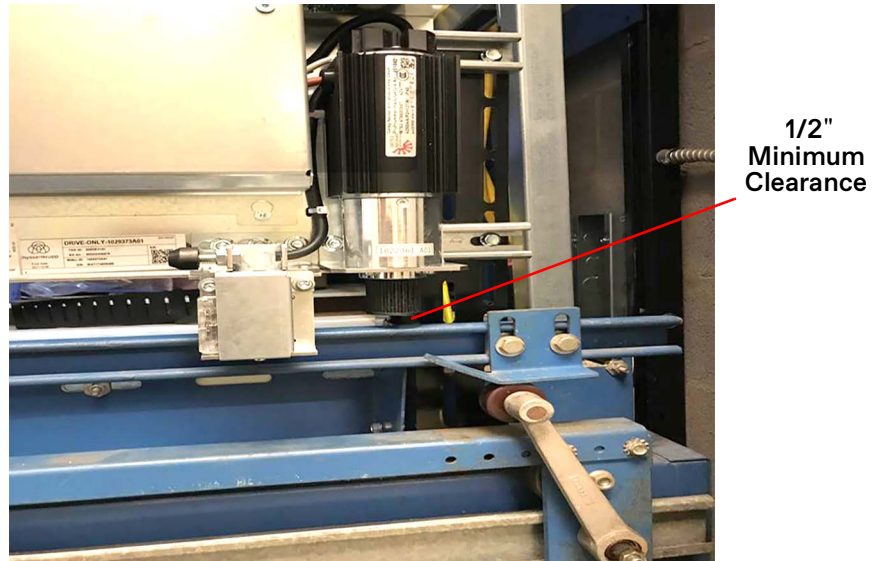

Figure 4 - Door Operator Drive Pulley Clearance

5. Install the drive arm. See Figure 5.
  - a. Use the included hardware to install the drive arm as close to the closed side of the car door as possible and still allow the drive arm to clear the existing clutch and clutch linkage. The door controller is now accessible in the door opening.
  - b. Move the door operator controller box from left to right and mount the drive arm. The gate switch and the door stop bumper are now functional.

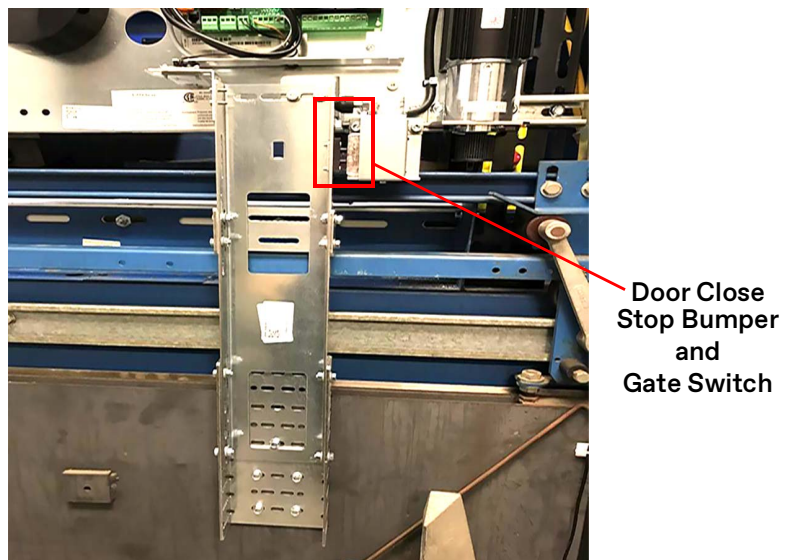

Figure 5 - Install the Drive Arm



## Installation (continued)

6. Adjust the gate switch and the door stop bumper. See .
  - a. With the car door closed, adjust the gate switch so that it is centered on the contacts with an  $\frac{1}{8}$ " compression.
  - b. Ensure that the car door is fully closed in the original position, so that the pick-up rollers do not need re-adjusting.
  - c. Adjust the door close stop bumper so that it makes contact with the door drive arm with the car door in the closed position.

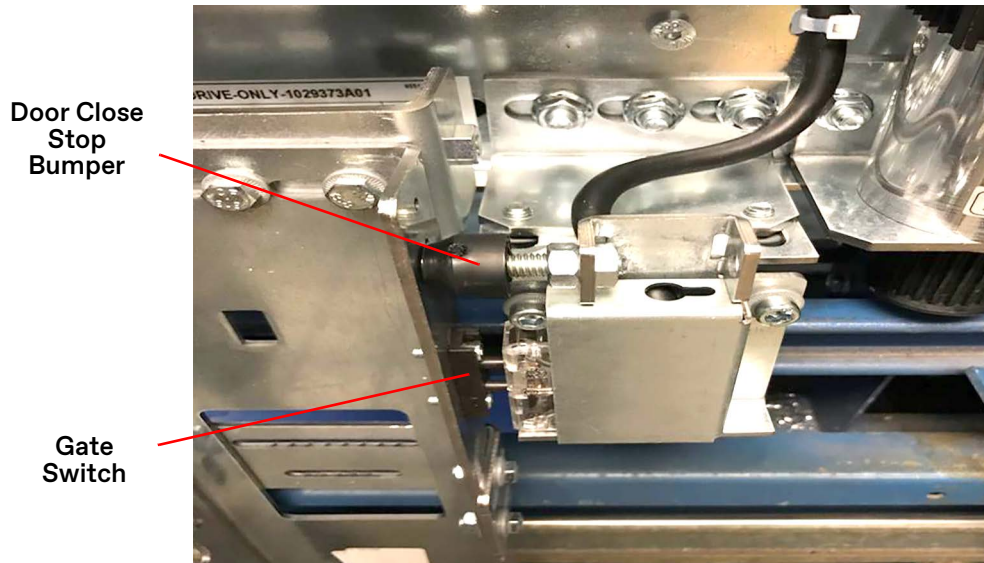

Figure 6 - Adjust Gate Switch and Door Stop Bumper

7. Install the door open stop bracket to the unistrut so that the car door opens to the original open position. See .



Figure 7- Door Open Stop Bracket Installation

8. Install the belt tensioner behind the door open stop bracket with 2 inches of clearance of both sides for belt stretch. See Figure 8.

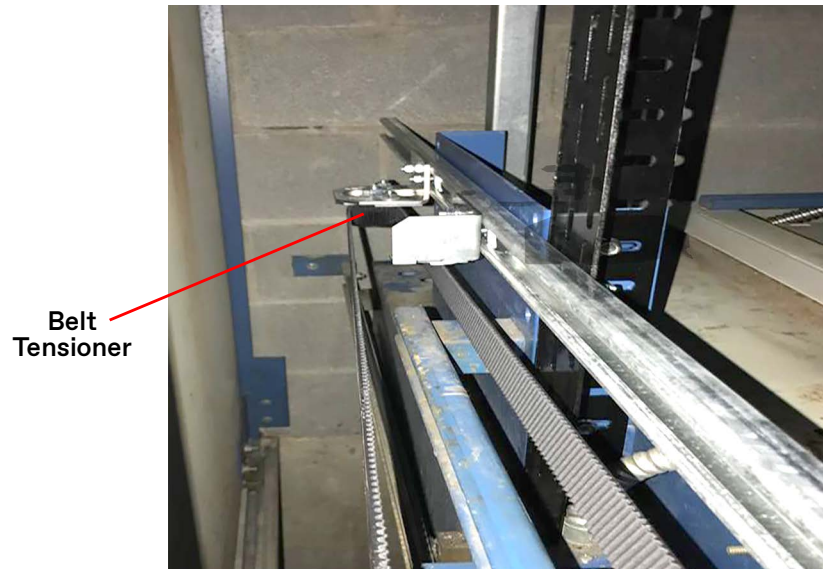

Figure 8 - Belt Tensioner Installation

9. Install the drive belt. See .
  - a. Use the fixing screw to install the belt coupler into the drive arm.
  - b. Install the belt around the drive motor and then around the auxiliary open.
  - c. With the door closed, pull the belt tight and mark location of the belt cut length.
  - d. Use the proper cutting tool to cut the four stainless steel cables inside the belt.
  - e. Verify that the belt installation looks the same as Figure 10 on page 15.

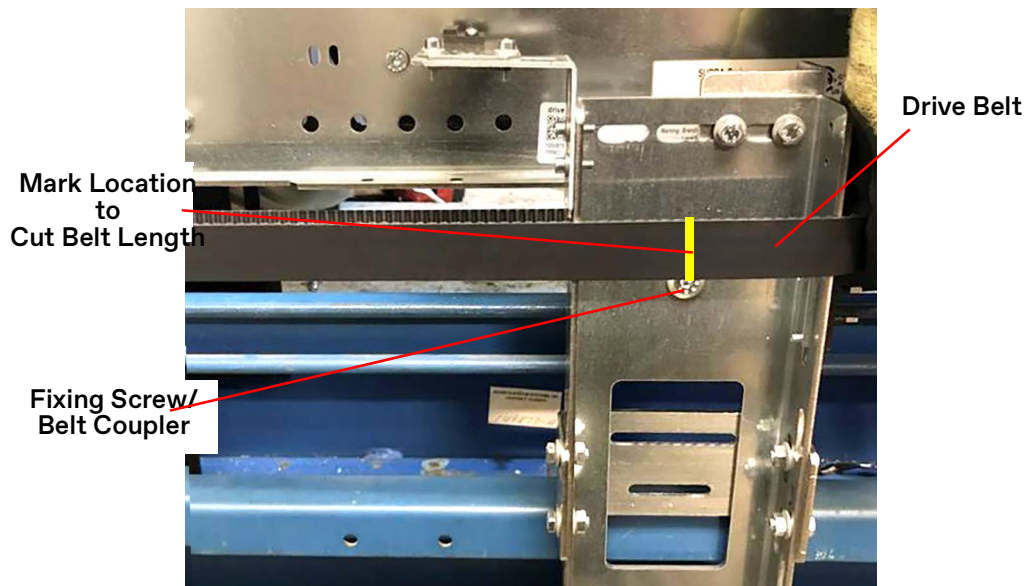

Figure 9 - Drive Belt Installation

## Installation (continued)

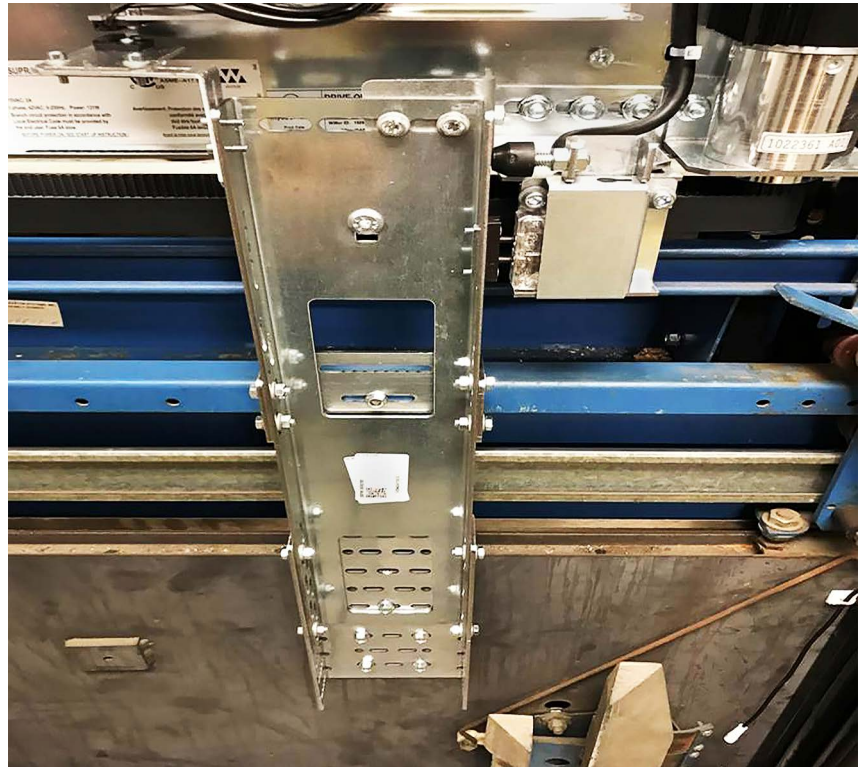

Figure 10 - Pin the Drive Arm/Completed Belt Installation

10. Use a  $\frac{1}{4}$ " - 20 bolt to pin the drive arm to the door hanger to increase the strength of the drive arm. See Figure 11.
11. Use a  $\frac{3}{8}$ " tek screw to mount the drive arm to the car door.

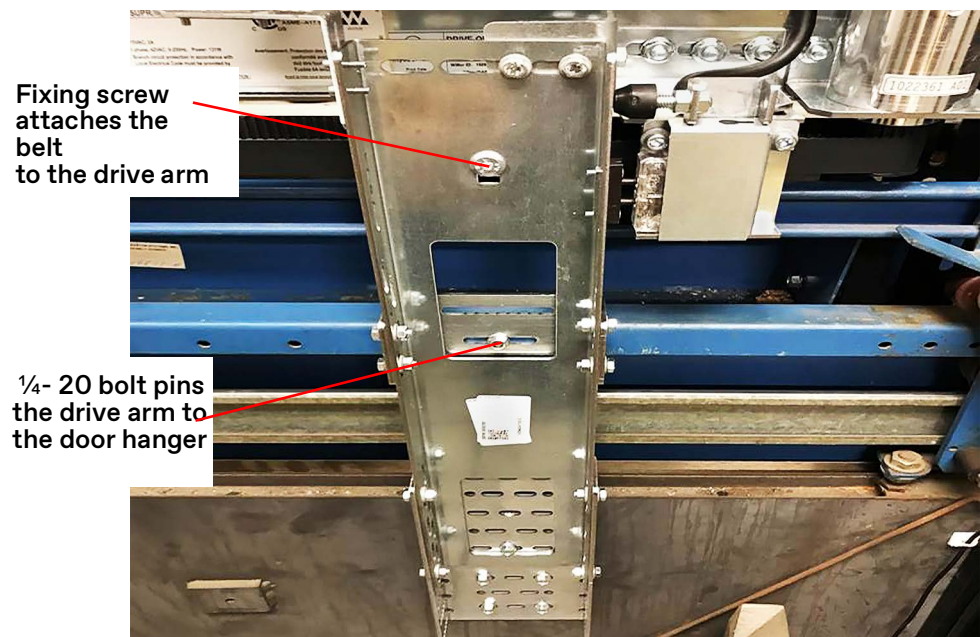

Figure 11 - Pin the Drive Arm/Completed Belt Installation

Installation  
 (continued)

12. Use the included hardware to install the reference switch bracket on either side of the drive arm. The reference switch bracket can be adjusted up, down, and side-ways.
13. Verify that the REFRSW (reference switch) LED activates approximately  $\frac{1}{2}$ " before the door is closed. See Figure 12.

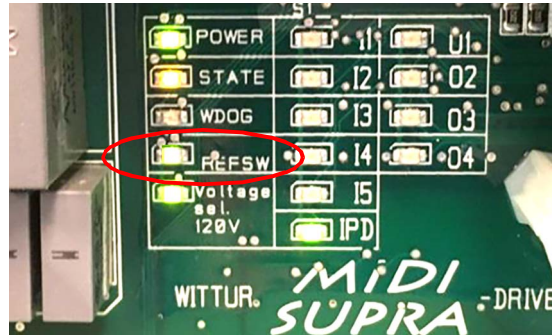

Figure 12 - Activated REFRSW (reference switch) LED

14. Install the following wiring components. For complete installation, see Figure 13 (SS) and Figure 14 on page 17 (CO).
  - a. Car top station.
    - Pendant station.
    - Car top work light.
    - Fixed stop switch/GFCI/alarm bell.
  - b. Auxiliary lighting box.
  - c. Extension harness wires from the COP to the door operator wireway box.

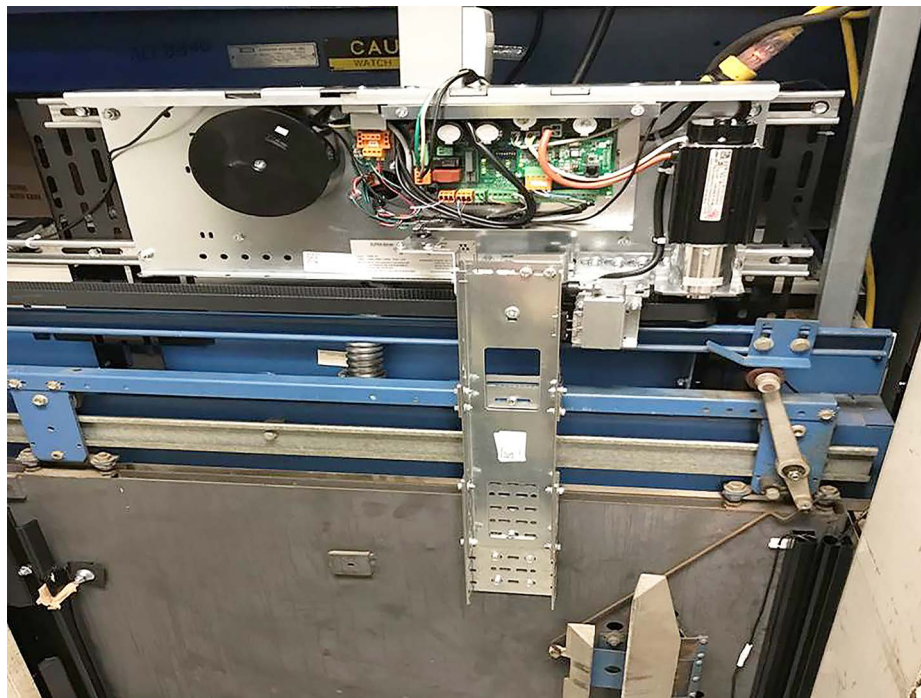

Figure 13 - Installed Door Controller Wiring (SS)

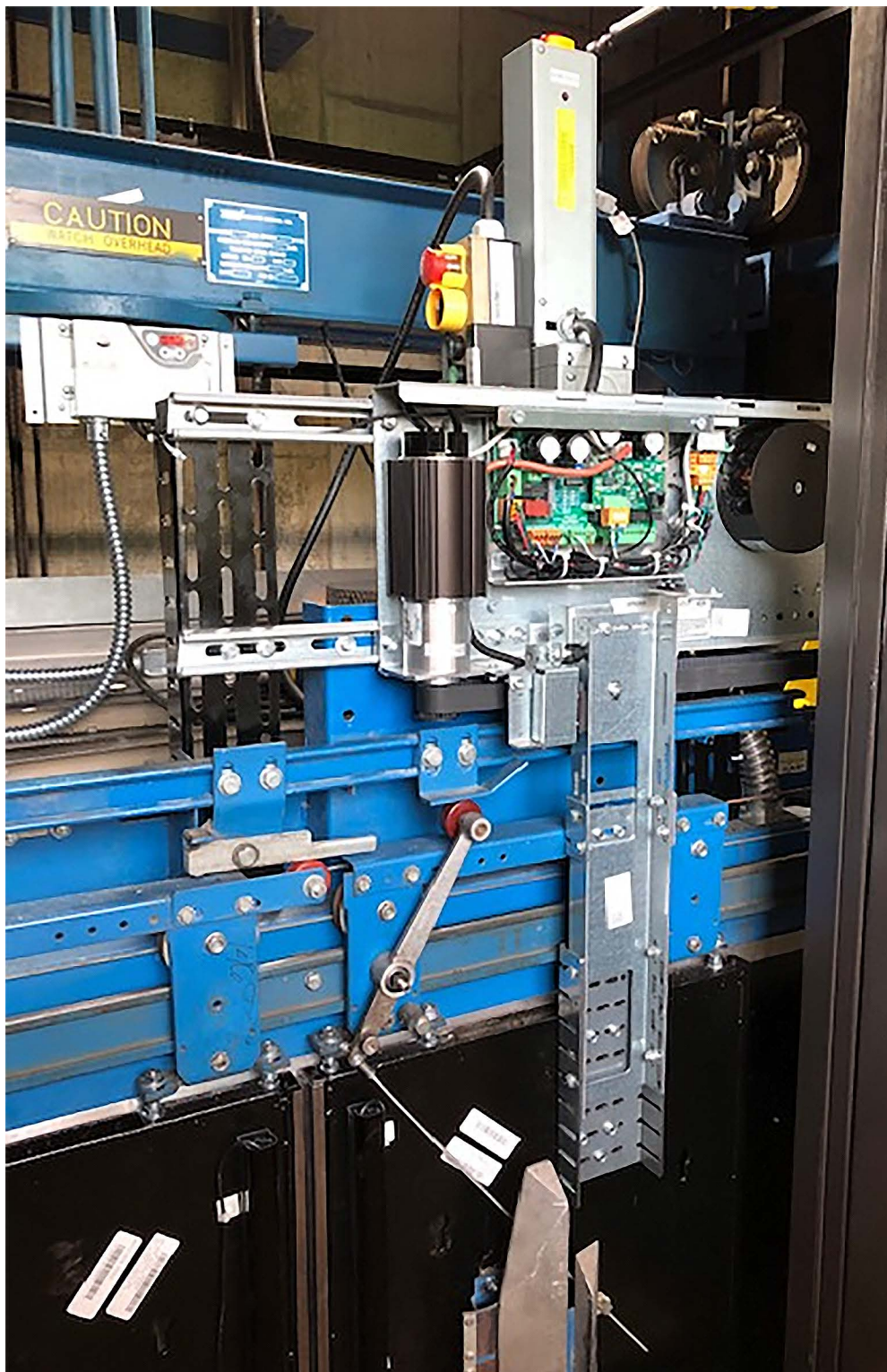

Figure 14 - Installed Door Controller Wiring (CO)

# Replacement Parts

Print No.	Part No.	Description
200CEV001	9735422	Door Drive Kit
200CEV101	9734934	Door Drive Kit
186FE001	9734790	Car Top Inspection Station, Front
186FE002	9734892	Car Top Inspection Station, Rear
364AA25	9735033	Cedes Mini-32-NB Door Protective Device
196DTA001	9735136	Pulley Bracket Assembly
200CRM001	9736013	Cable Tie Kit
200CTB001	9736116	Car Top Light Kit
200CMM001	9736311	Door Weight Label Kit
546WX003	9736517	LD-16 Junction Box Assembly
200CLY001	9736712	Door Operator Mounting Kit
200CTN001	9736815	Clutch Actuation Kit
196BBH001	9737716	Relating Cable Bracket Assembly
200CJY001	9734697	Serial Interface PCB Kit
—	9736918	Wittur Programming Tool (WPT)
Door Operator Harness		Location
462AEN005	9734843	COP Extension, Discrete, Front
462AEN006	9735045	COP Extension, Discrete, Rear
462AEN007	9735240	COP Extension, Front
462AEN008	9734855	COP & CTB Extension, Rear
462AEN009	9734958	CTB Extension, Front
462AEN010	9735458	COP Extension, Front
462AEN011	9735756	COP & CTB Extension, Rear
462AEN012	9733760	CTB Extension, Front
462AEM001	9734764	COP Adapter, Front, TAC32T
462AEM004	9735367	COP Adapter, Front, TAC32H
462AEM006	9735562	COP Adapter, Front, FUTURA T, TAC50-04
462AEM008	9734570	COP Adapter, Front
462AEM010	9734673	COP Adapter, Inspection, TAC32T
462AEM011	9734776	COP Adapter, Inspection
462AEM012	9734879	COP Adapter, Alarm, Front
462AEM013	9734971	COP Adapter, Alarm, Front
462AEM002	9735379	COP Adapter, Rear, TAC32T
462AEM005	9734788	COP Adapter, Rear, TAC32H
462AEM007	9734983	COP Adapter, Rear, FUTURA T, TAC50-04
462AEM009	9735185	COP Adapter, Rear
462AEM014	9735288	COP Adapter, Front
462AEM016	9735380	COP Adapter, Alarm, Rear
C/O Relating Cable Kits		Door Opening Width
200CMG001	9735094	24"-26"
200CMG002	9735197	27"-29"
200CMG003	9735495	30"-32"
200CMG004	9736001	33"-35"
200CMG005	9736207	36"-38"
200CMG006	9736300	39"-41"
200CMG007	9736402	42"-44"
200CMG008	9736608	45"-47"
200CMG009	9736803	48"-50"
200CMG010	9736906	51"-56"
200CMG011	9737509	57"-59"

## Replacement Parts

(continued)

Door Drive Kit	
Print No.	Part No.
200CEV001, LH (shown)	9735422
200CEV101, RH	9734934

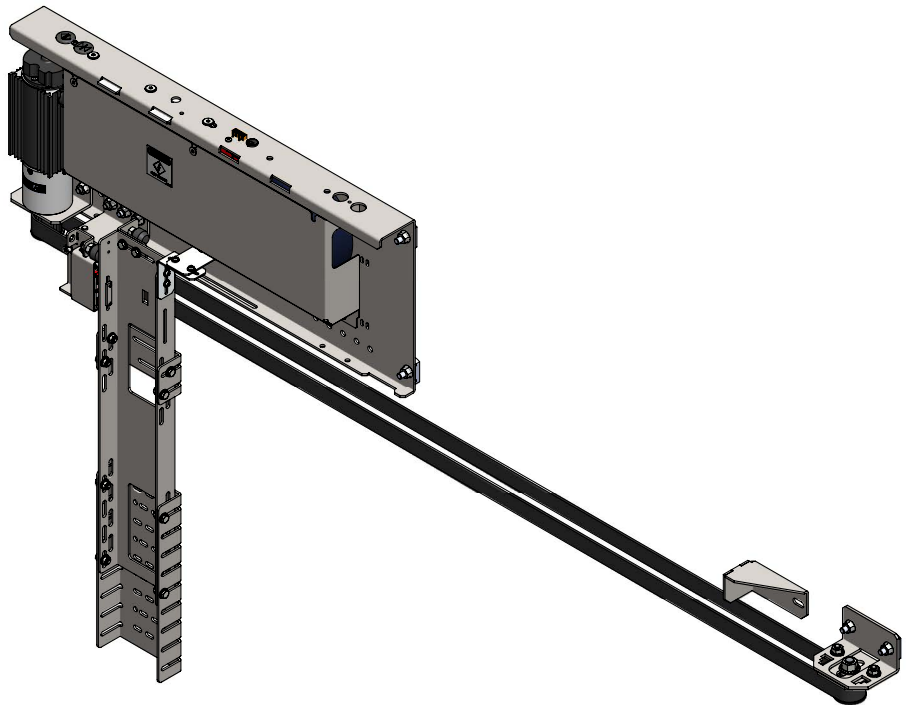

Car Top Station Assembly	
Print No.	Part No.
186FE001, Front	9734790
186FE002, Rear	9734892

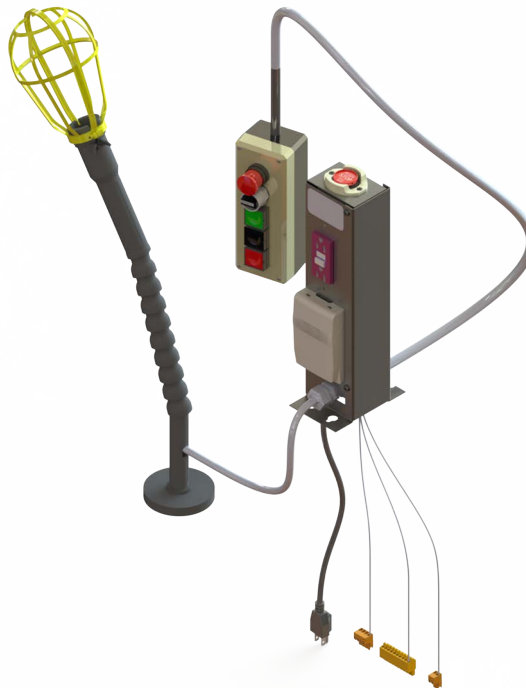

Replacement Parts  
(continued)

**Door Operator Mounting Kit**  
Note: wiring kit not shown

Print No. 200CLY001  
Part No. 9736712

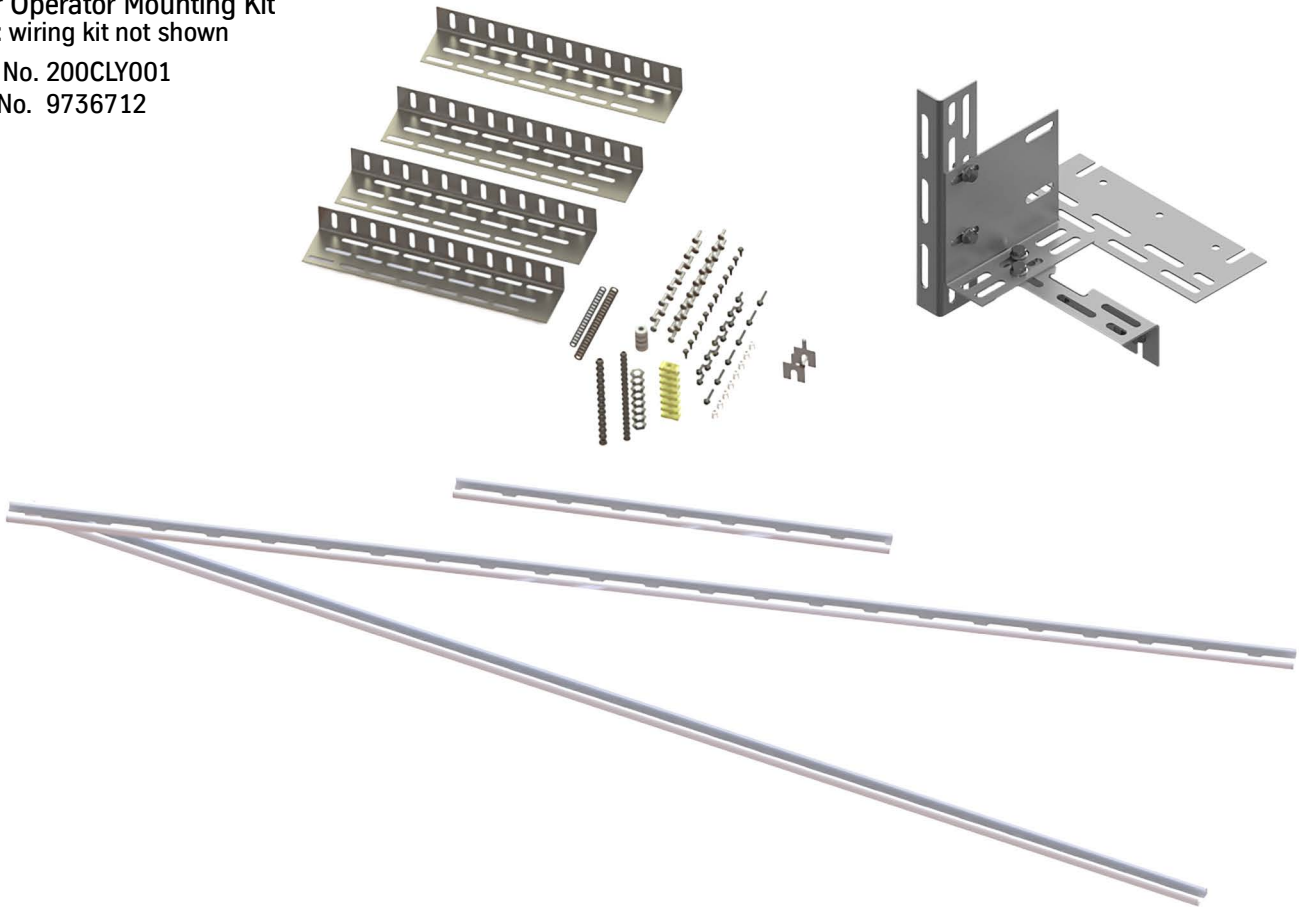

**Serial Interface Kit**

Print No. 200CJY001  
Part No. 9734697

- Kit includes
- 6300AFM003 (shown)
  - standoffs
  - adhesive

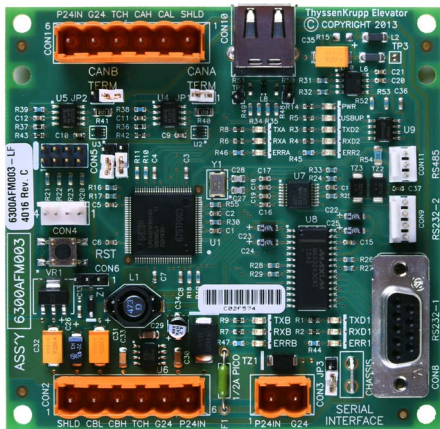

**Junction Box Assembly**

Print No. 546WX003  
Part No. 9736517

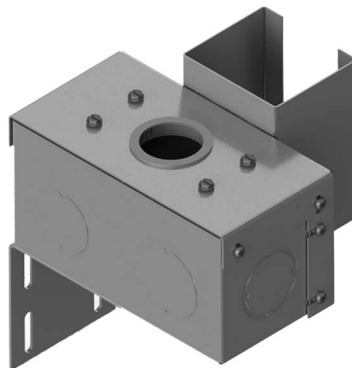

**Pulley Bracket Assembly**

Print No. 196DTA001  
Part No. 9735136

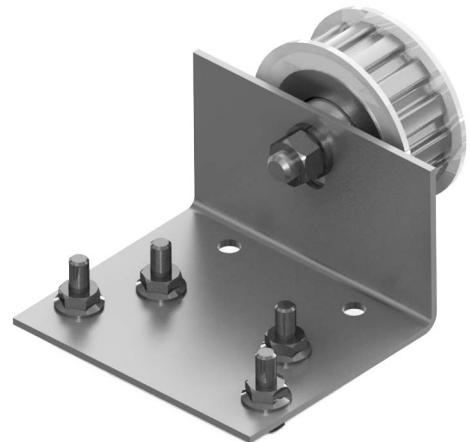



Replacement Parts  
(continued)

GAL Relating Cable Kit, C/O		
DOW	Print No.	Part No.
24"- 26"	200CMG00 1	973509 4
27"- 29"	200CMG00 2	973519 7
30"- 32"	200CMG00 3	973549 5
33"- 35"	200CMG00 4	973600 1
36"- 38"	200CMG00 5	973620 7
39"- 41"	200CMG00 6	973630 0
42"- 44"	200CMG00 7	973640 2

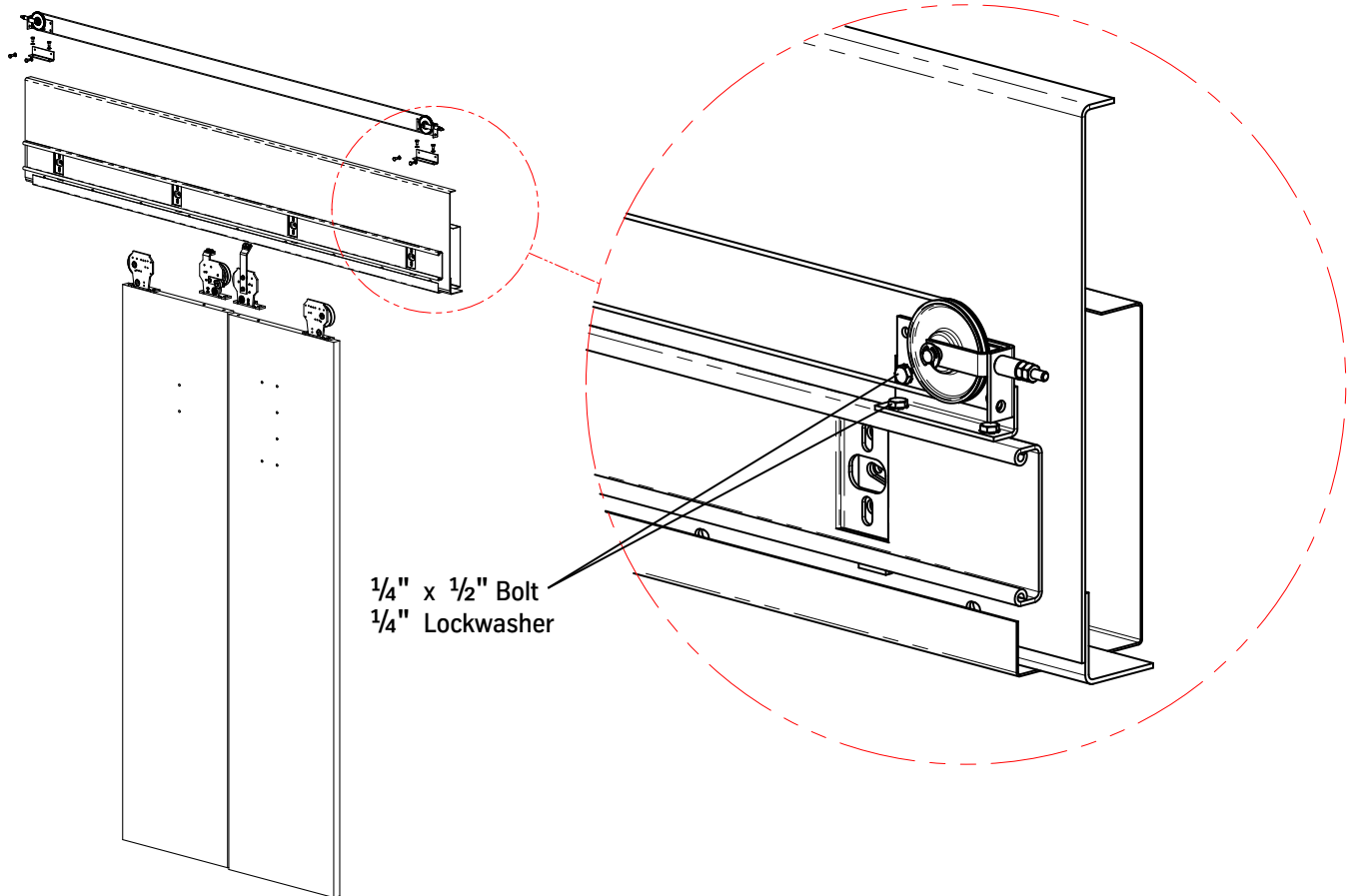
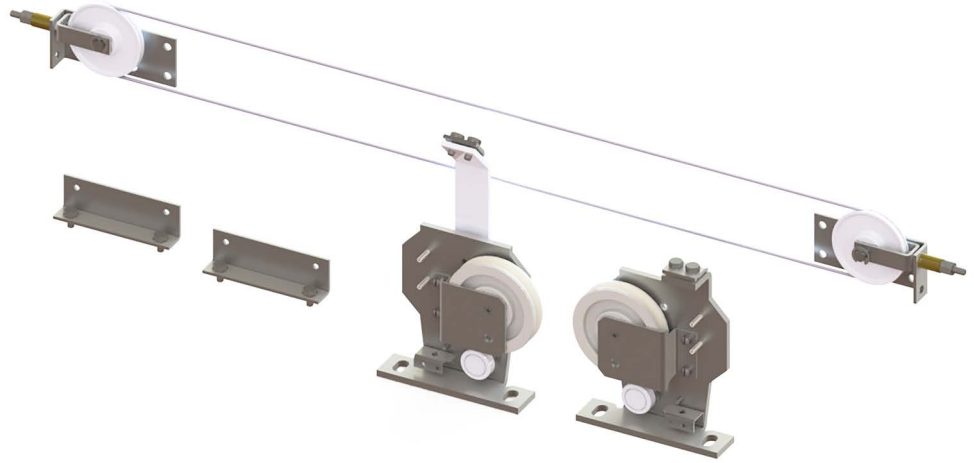

Replacement Parts  
(continued)

Clutch Actuation Kit

Print No. 200CTN001

Part No. 9736815

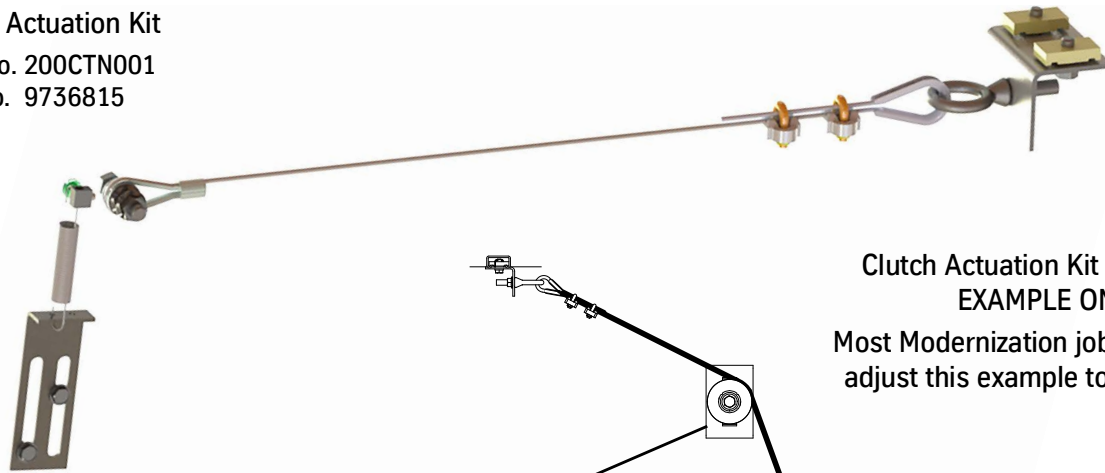

Clutch Actuation Kit Installation  
EXAMPLE ONLY

Most Modernization jobs are unique;  
adjust this example to the job site.

Relating Cable Bracket Assy.

Print No. 196BBH001

Part No. 9737716

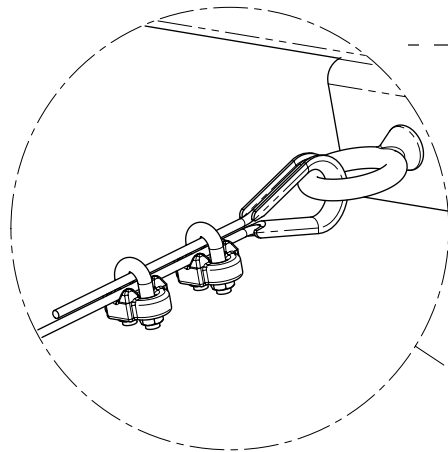

Strut from Mounting Kit 200CLY001 Attached to the Cab

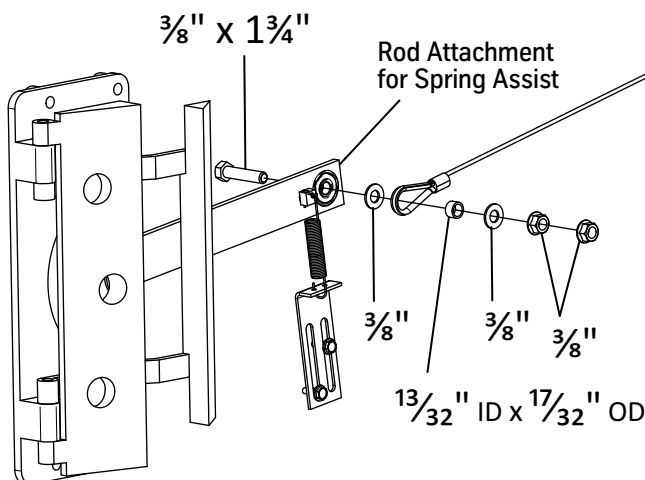
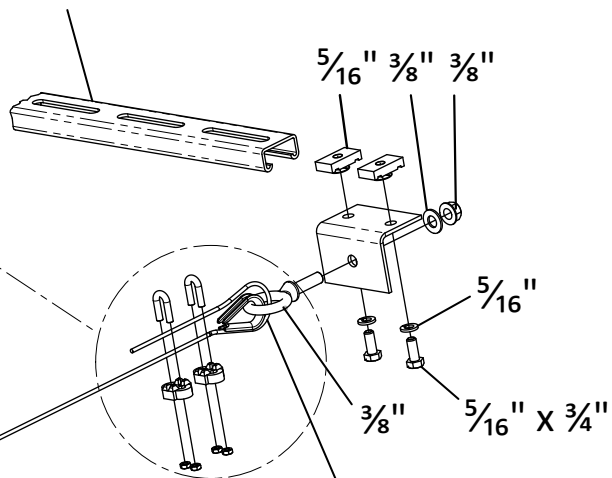

Attach the End of the Cable  
Without the Thimble to the Eyebolt

Replacement Parts  
*(continued)*

Wittur Programming Tool (WPT)  
Part No. 9736918



### Harness Assemblies with Diagrams - COP Adapter Harnesses, 462AEM\_



COP Extension Harnesses, 462AEN\_ starts on page 29.

Type: Door Operator  
 Use: TAC32T  
 Front: 462AEM001  
 Rear: 462AEM002

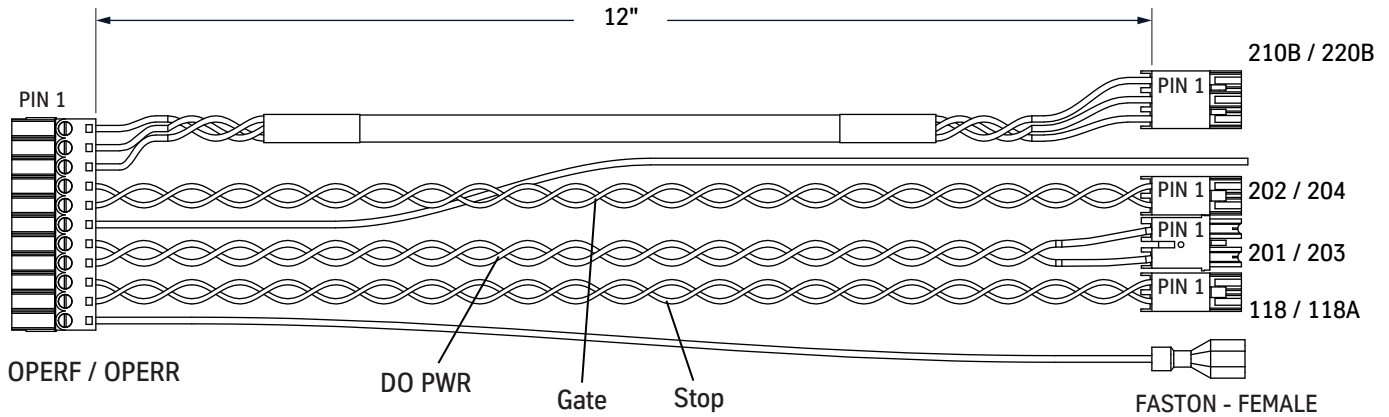

Type: Door Operator  
 Use: TAC32H  
 Front: 462AEM004  
 Rear: 462AEM005

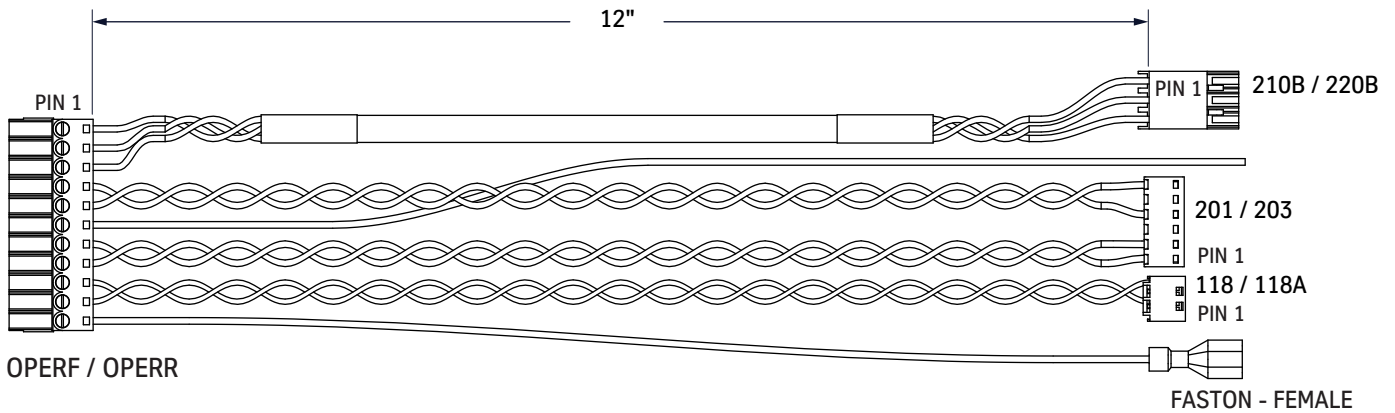

Harness Assemblies with Diagrams - COP Adapter, 462AEM\_  
(continued)

Type: Door Operator  
Use: Futura T, TAC50-04  
Front: 462AEM006

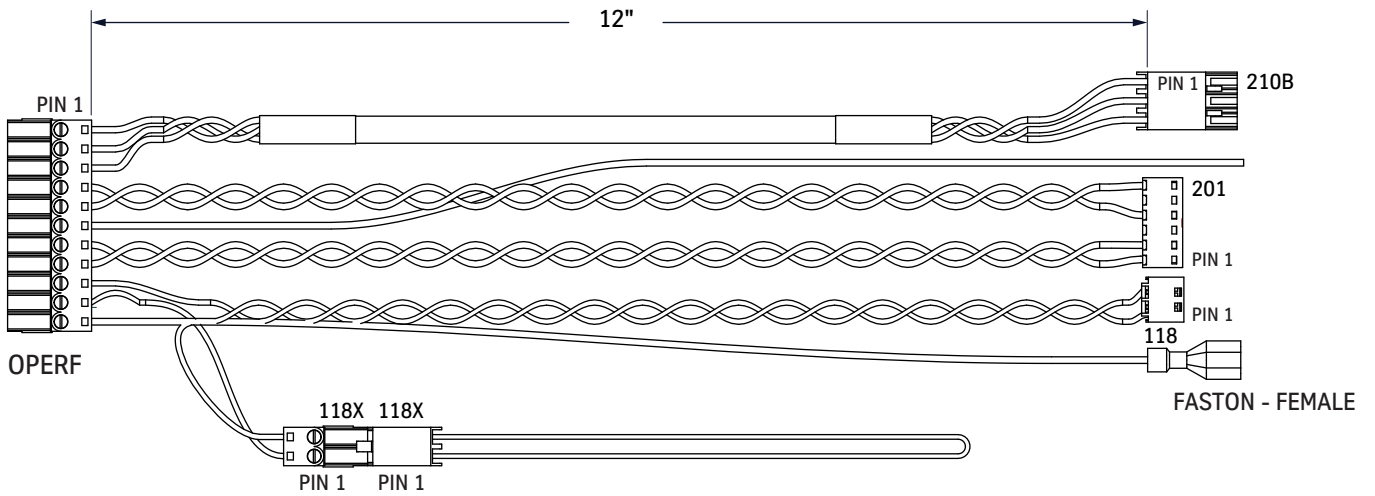

Type: Door Operator  
Use: Futura T, TAC50-04  
Rear: 462AEM007

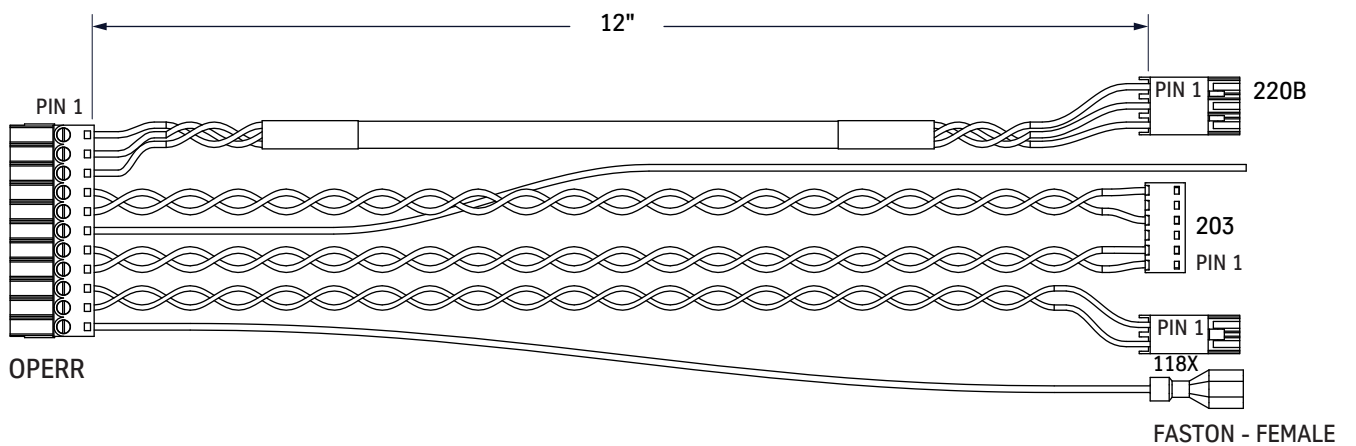

Harness Assemblies with Diagrams - COP Adapter, 462AEM\_  
(continued)

Type: Door Operator  
Use: TAC22, ICON, TAC20-03, TAC20, TAC50-03  
Front: 462AEM008

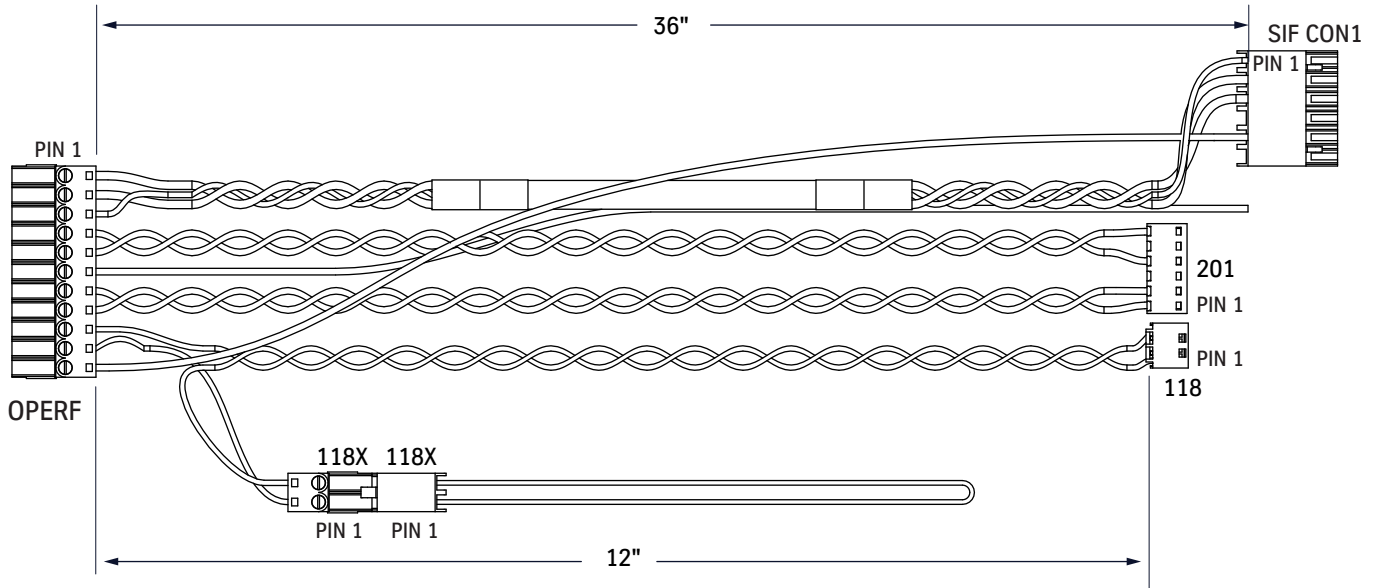

Type: Door Operator  
Use: TAC22, ICON, TAC20-03, TAC20, TAC50-03  
Rear: 462AEM009

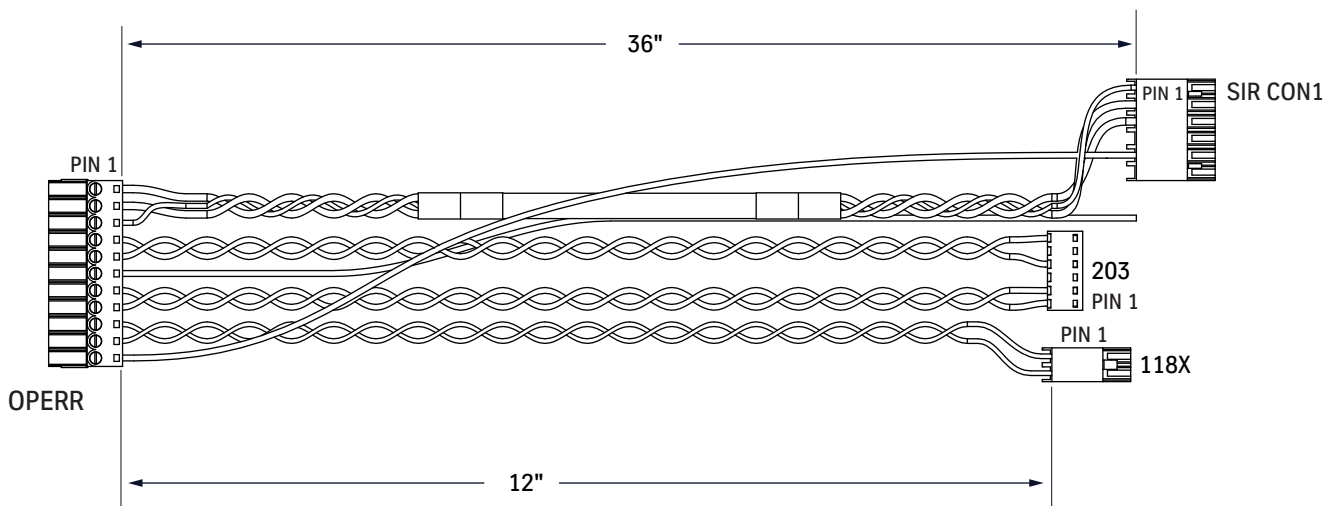

Harness Assemblies with Diagrams - COP Adapter, 462AEM\_  
(continued)

Type: Inspection  
Use: TAC32T  
Front: 462AEM010

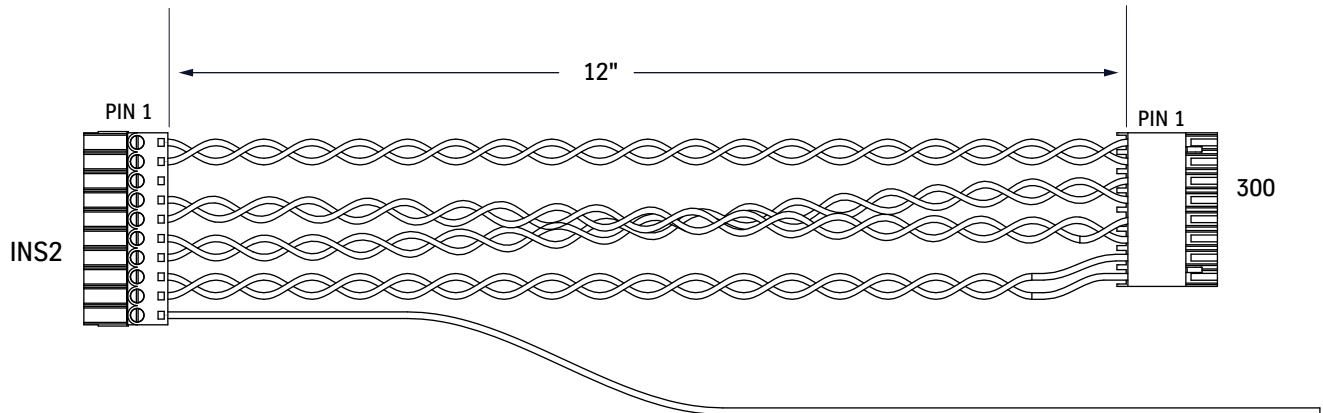

Type: Inspection  
Use: TAC32H, FUTURA T, TAC50-04, TAC22, ICON, TAC20-03, TAC20, TAC50-03  
Front: 462AEM011

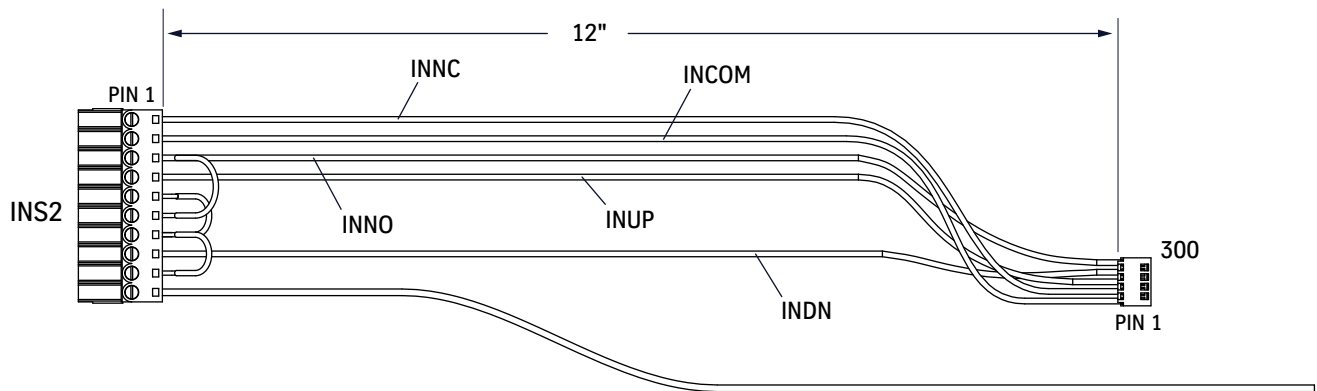

Type: Alarm  
Use: TAC32T, TAC32H, FUTURA T, TAC50-04  
Front: 462AEM012

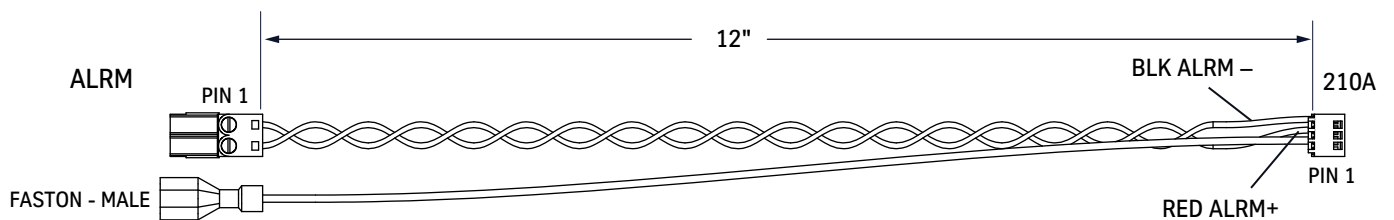

Harness Assemblies with Diagrams - COP Adapter, 462AEM\_  
(continued)

Type: Alarm, 485  
Use: TAC22, ICON, TAC20-03, TAC20, TAC50-03  
Front: 462AEM0013

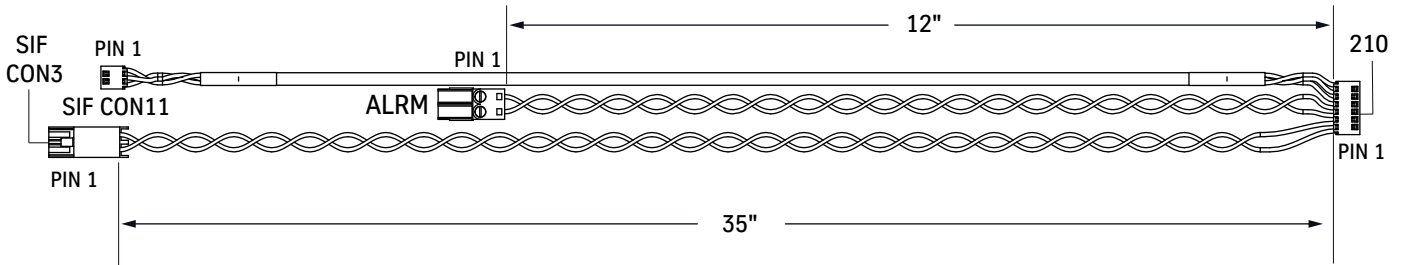

Type: Alarm, 485  
Use: TAC22, ICON, TAC20-03, TAC20, TAC50-03  
Rear: 462AEM0014

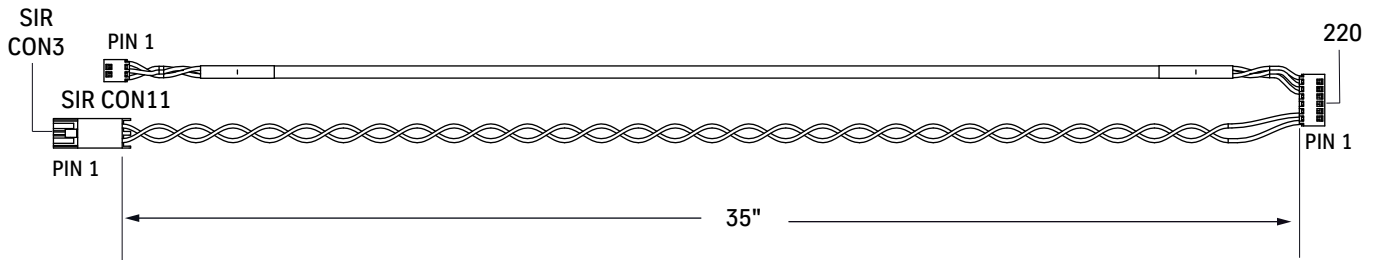

Type: Door Operator Ground  
Use: TAC32T, TAC32H, FUTURA T, TAC50-04  
Rear: 462AEM016

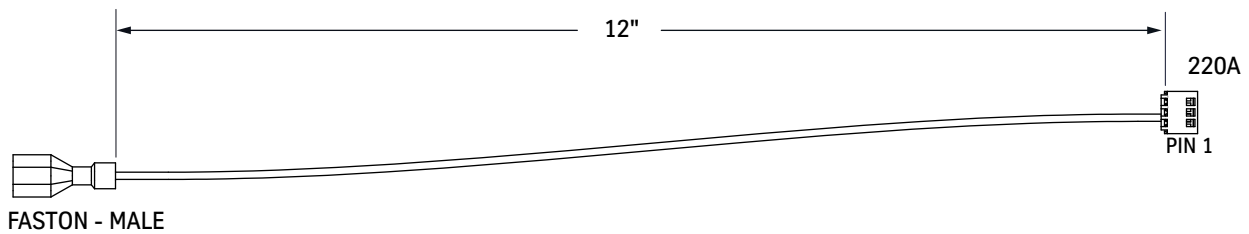



# Harness Assemblies with Diagrams - COP Extension Harnesses, 462AEN\_

Type: Discrete  
Use: Add On  
Print No: Front, 462AEN005  
Print No: Rear, 462AEN006

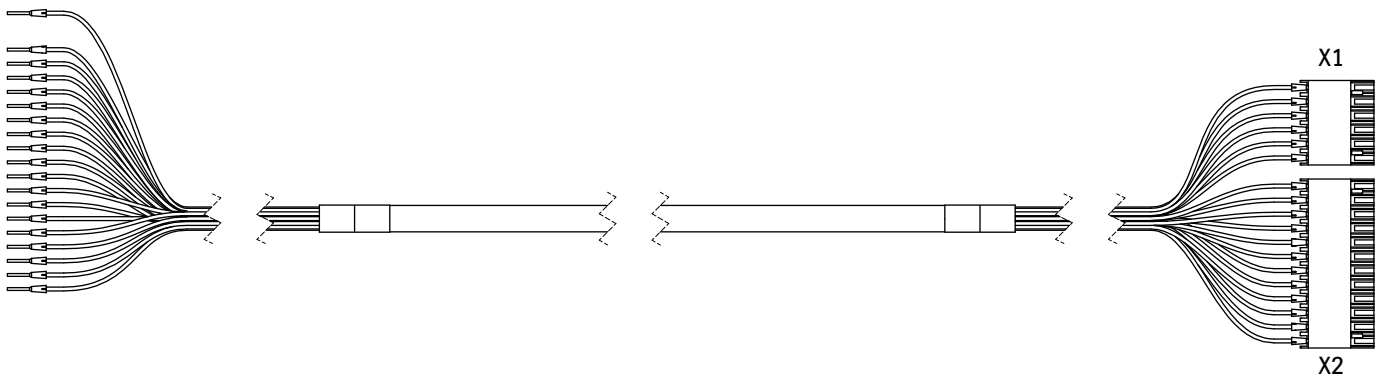

Type: COP, COP/CTB  
Use: Door Operator  
Print No: Front, 462AEN007 (COP)  
Print No: Rear, 462AEN008 (COP & CTB)  
Print No: Front, 462AEN009 (CTB)

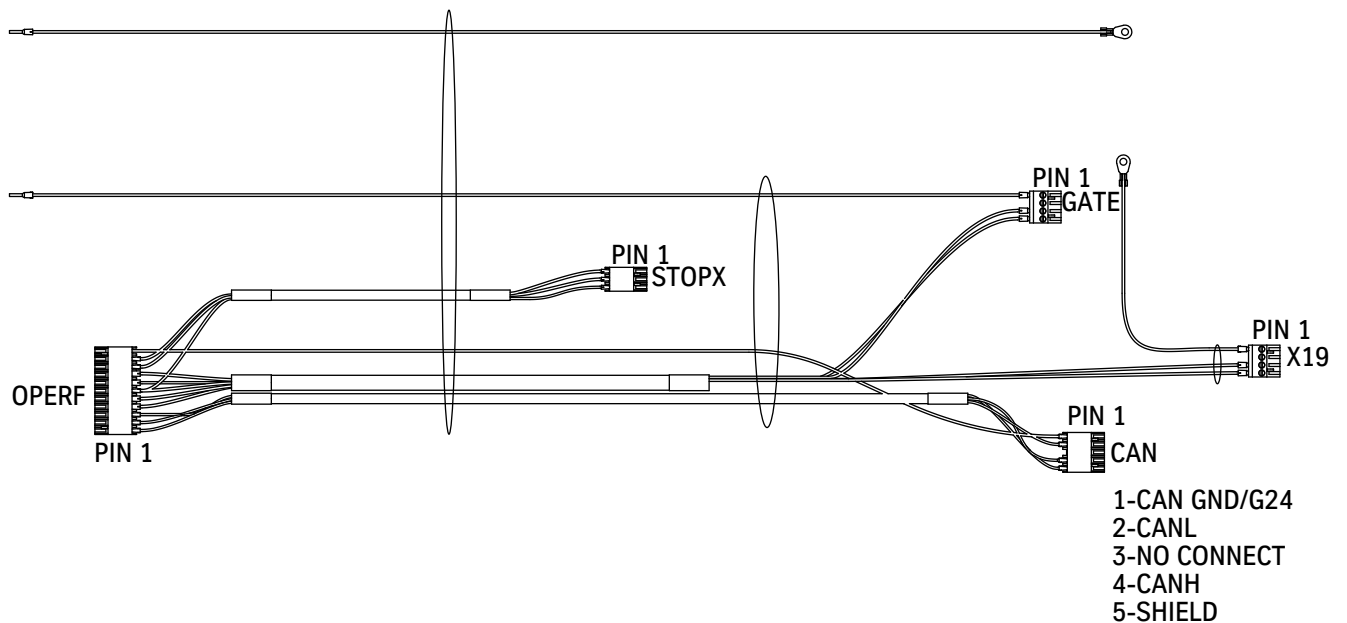

Harness Assemblies with Diagrams - COP Extension, 462AEN\_  
(continued)

Type: COP  
Use: Car Top Station  
Print No: Front, 462AEN010

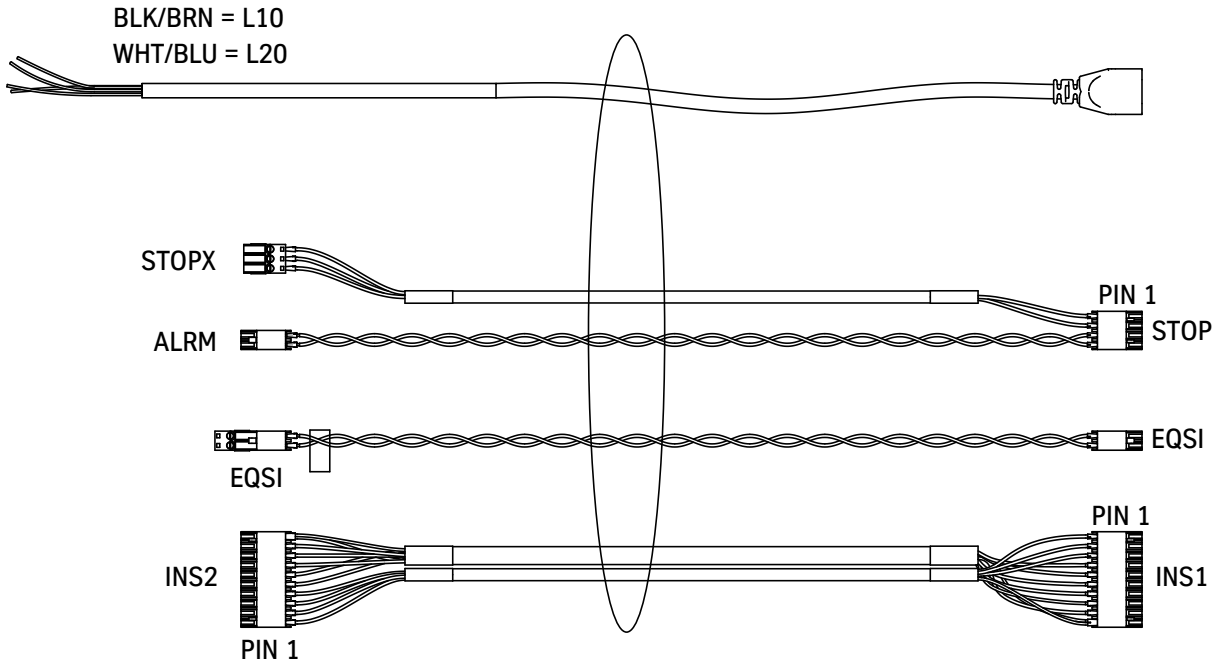

Type: COP, COP/CTB  
Use: Car Top Station  
Print No: Rear, 462AEN0011  
Print No: Front, 462AEN0012

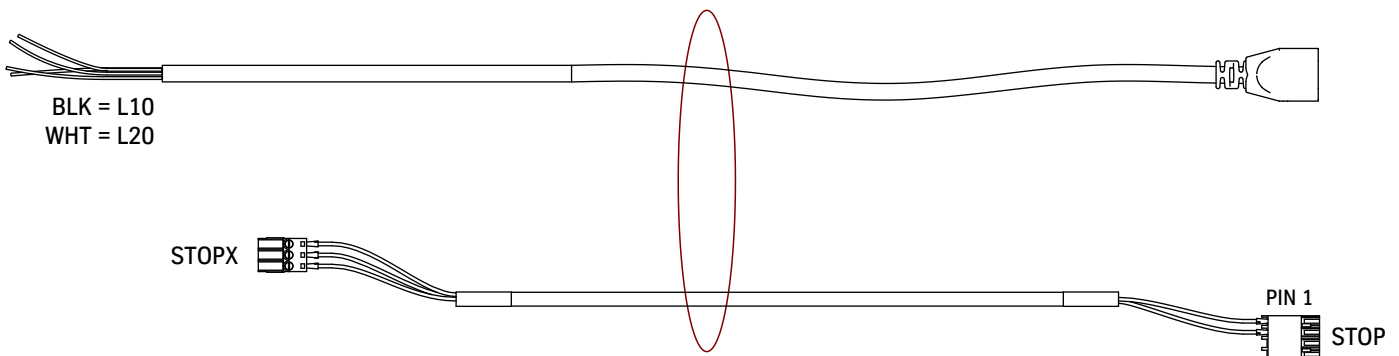

# Generic Wiring Diagrams

## DISCRETE CONTROLLER - FRONT

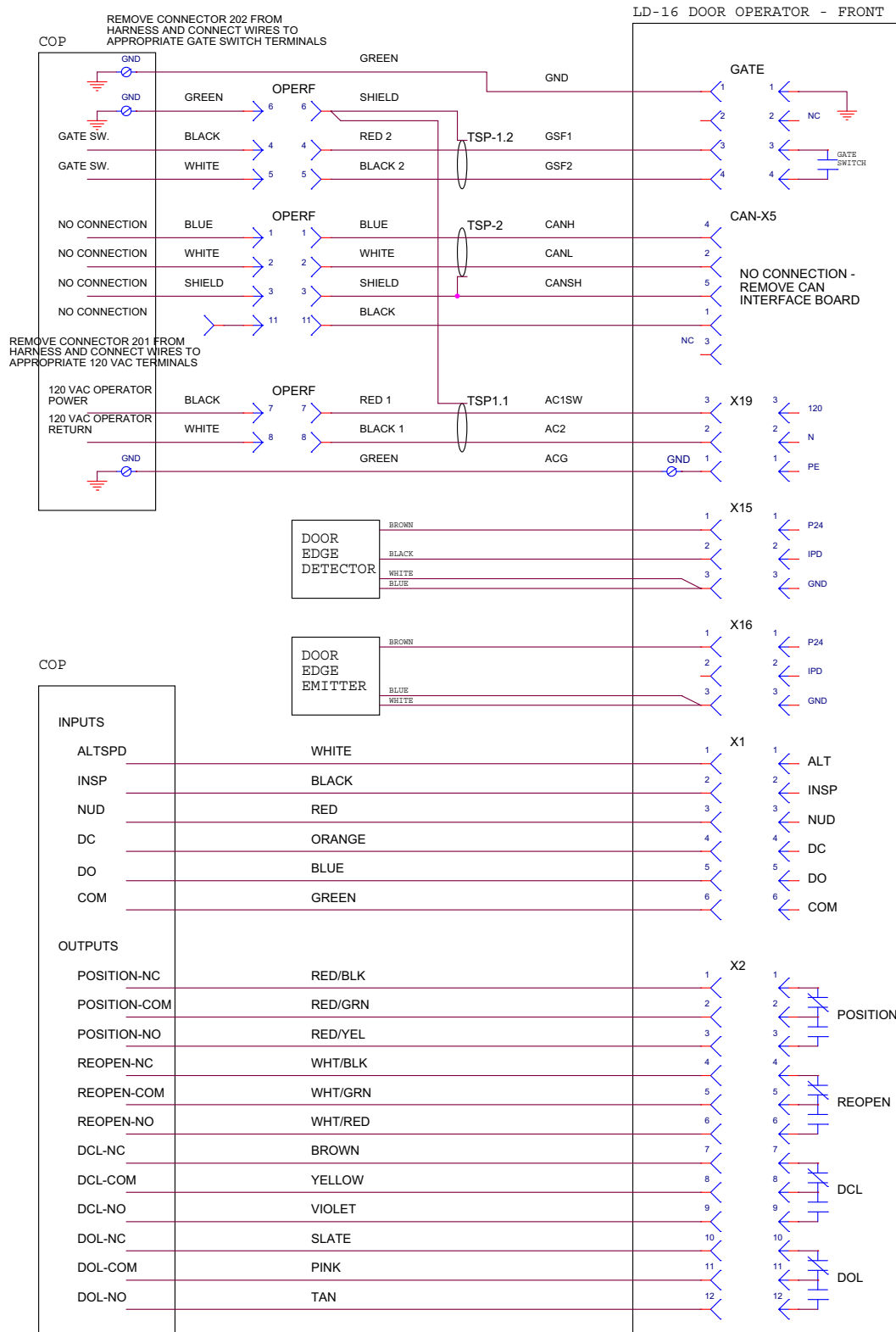

# DISCRETE CONTROLLER - FRONT

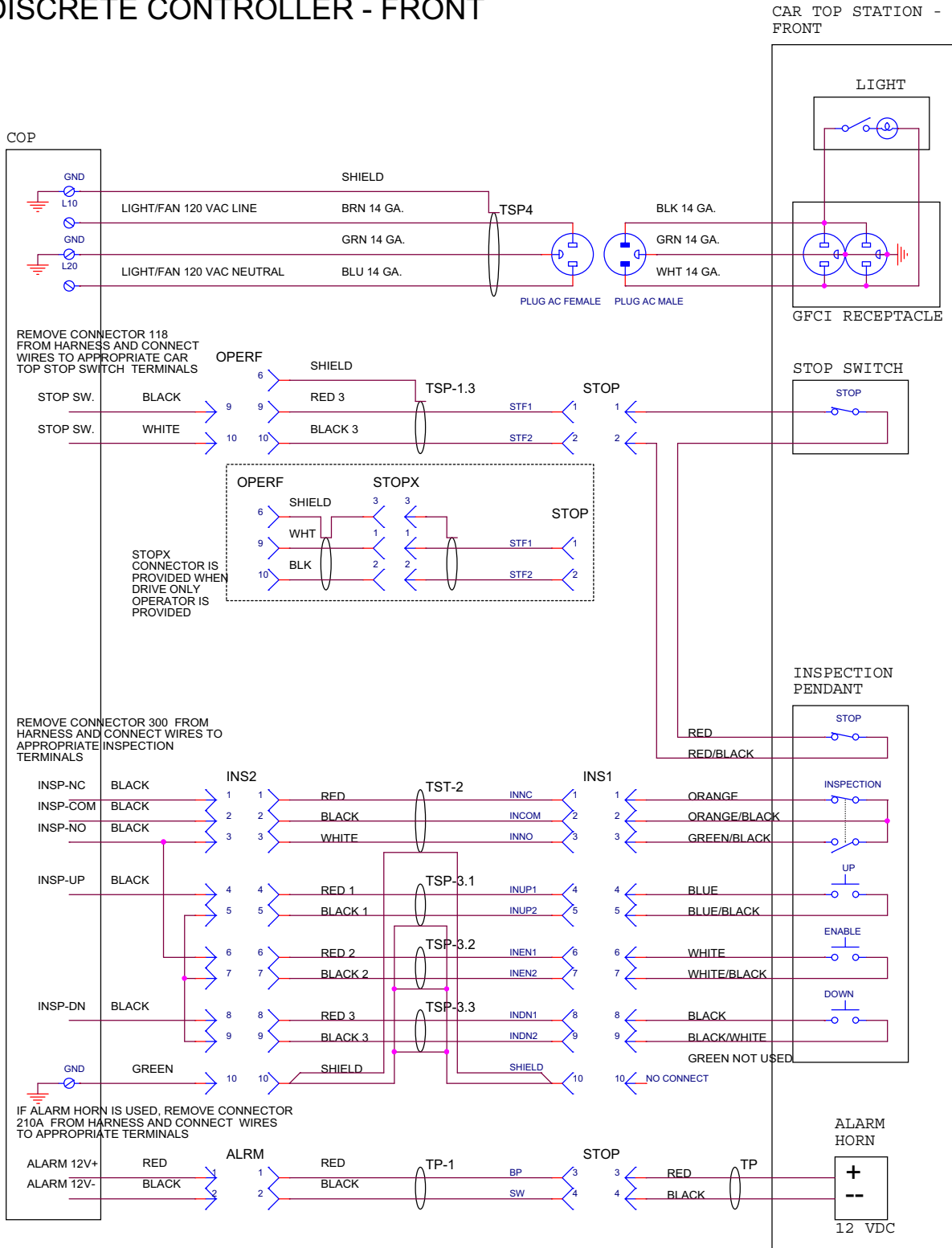

# DISCRETE CONTROLLER - REAR

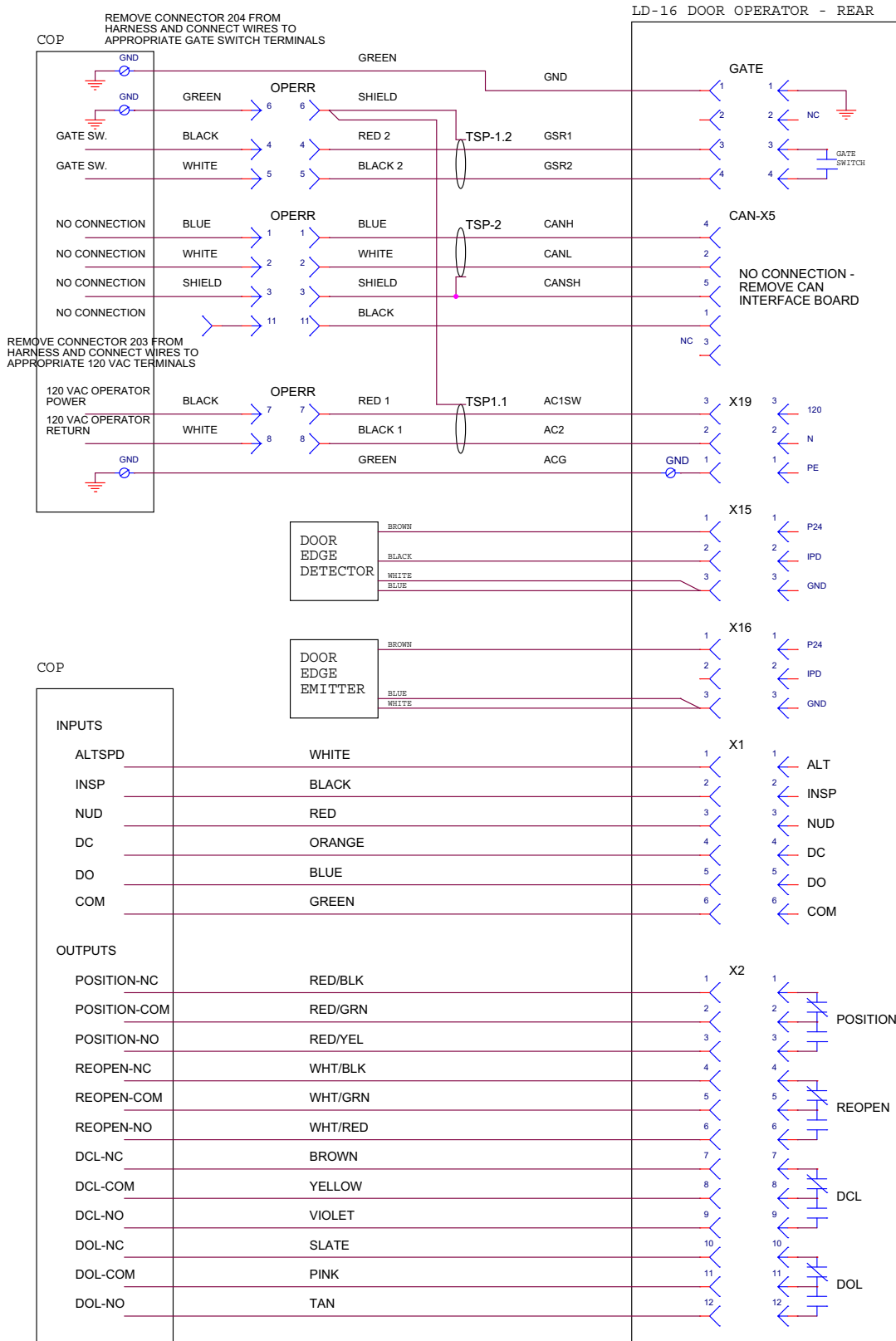

# DISCRETE CONTROLLER - REAR

## CAR TOP STATION - REAR

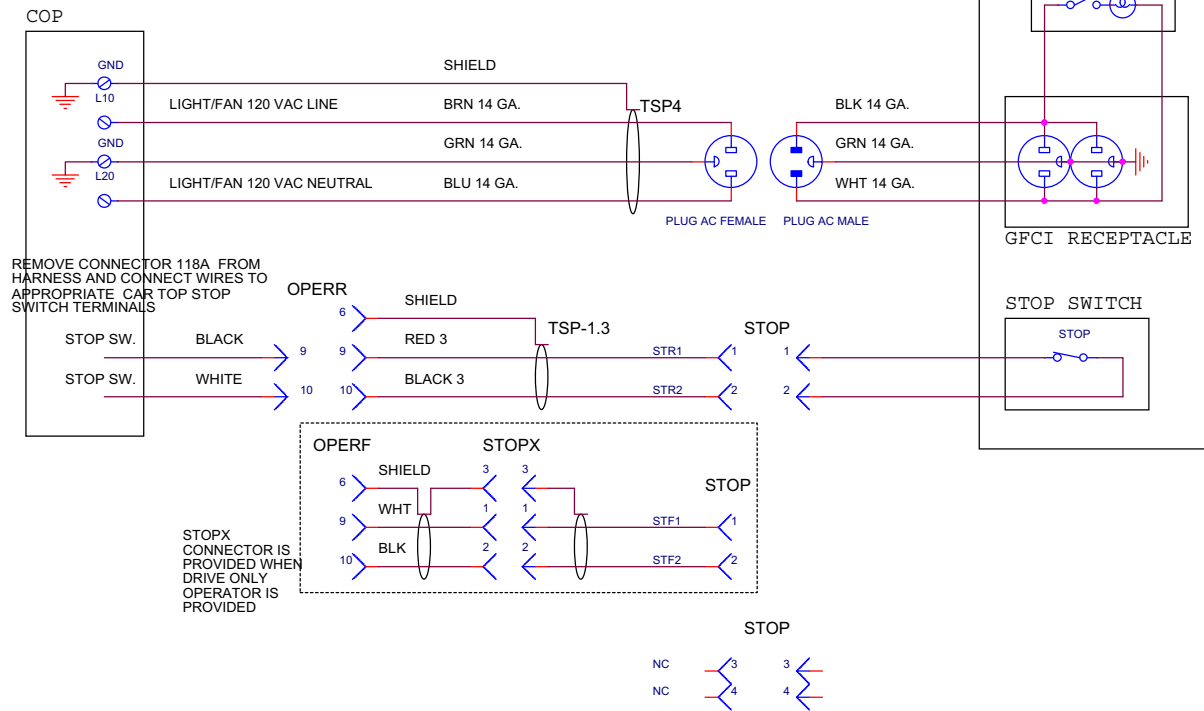



**VERTICAL EXPRESS**

9280 Crestwyn Hills Memphis, TN 38125  
Tel: (866) 448-3789 (toll free) Fax: (901) 877-8099  
[www.verticalxpress.com](http://www.verticalxpress.com)

All illustrations and specifications are based on information in effect at time of publication approval. Vertical Express reserves the right to change specifications or design and to discontinue items without prior notice or obligation. © 2021 Vertical Express