

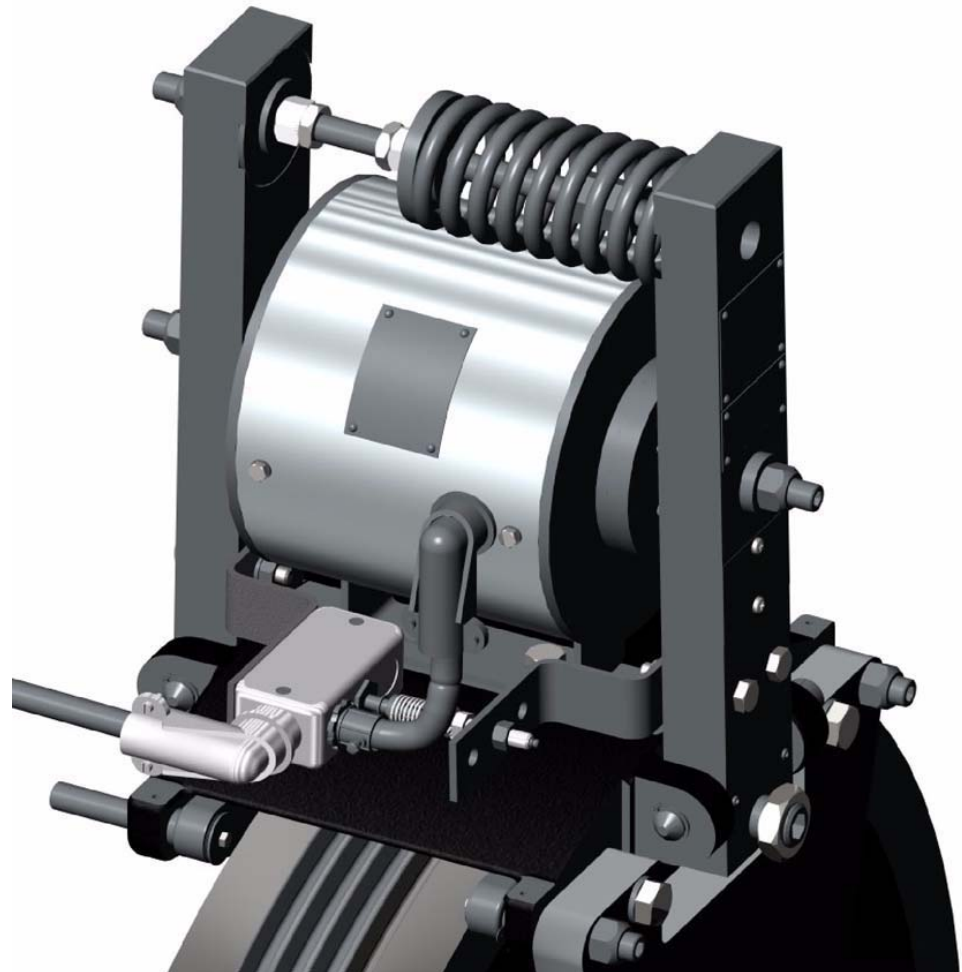

VERTICAL EXPRESS

GD-1 / GD-2 Sheave Brake



Every attempt has been made to ensure that this documentation is as accurate and up-to-date as possible. However, Vertical Express assumes no liability for consequences, directly or indirectly, resulting from any error or omission. The material contained herein is subject to revision. Please report any problems with this manual to Vertical Express, P.O. Box 2019, Memphis, Tennessee 38101.

Vertical Express • P.O. Box 2019 • Memphis, Tennessee 38101

© 2004, 2012 Vertical Express. All rights reserved.
Published January, 2012
Fifth Edition
Printed in the United States of America

Manual Number: 89166 v.1.1

Contents

Safety Precautions	3
Terms in This Manual	3
General Safety	3
Electrical Safety	3
Mechanical Safety	4
Handling	5
Shipping	5
Arrival of Equipment	5
Application	7
Overview	7
Specifications	7
Required Tools	7
Operation	8
Emergency Brake	8
Ascending Car Overspeed Protection	8
Unintended Car Movement Protection	8
Emergency Brake Operation	9
Sheave Brake Operation	9
Installation	11
GD-1 Sheave Brake Installation	11
GD-2 Sheave Brake and Brake Mount	15
Brake Shoe Installation	20
Sheave Brake Switch Relocation	23
Wiring	23
Sheave Brake Coil Wiring	23
Adjustments	24
Spring Adjustment	24
Armature Adjustment	25
Electrical Adjustments	26
Brake Shoe Adjustment	27
Maintenance	29
Sheave Brake	29

Contents

(continued)

Troubleshooting	29
Sheave Brake Faults	29
Sheave Brake I/O	29
Sheave Brake Relays and Contacts	30
Sheave Brake Contactors	30
TAC50 Sheave Brake Adjustments	31
TAC50 Sheave Brake Test Procedures	32
Ascending Car Overspeed Test	32
Unintended Motion Test	34
Ascending Overspeed Test TST7	36
Replacement Parts	40
205CT Sheave Brake Diagrams	40
205CT Sheave Brake, Lever Shaft Detail	41
205CT Sheave Brake, Spring Detail	41
205CT Sheave Brake Parts List	42
779AL Sheave Brake Solenoid Assembly	43
779AL Solenoid Assembly Parts List	44

Safety Precautions

IMPORTANT!

Read this page before any work is performed on elevator equipment. The procedures contained in this manual are intended for the use of qualified elevator personnel. In the interest of your personal safety and the safety of others, do not attempt any procedure that you are not qualified to perform.

All procedures must be accomplished in accordance with the applicable rules in the latest edition of the National Electrical Code, the latest edition of ASME A17.1, and any governing local codes.

Terms in This Manual



CAUTION statements identify conditions that may result in damage to the equipment or other property if improper procedures are followed.



WARNING statements identify conditions that may result in personal injury if improper procedures are followed.

General Safety



Before applying power to the controller, check that all factory wire connections are tight on relays, contactors, fuse blocks, resistors, and terminals on cards and DIN rail terminals. Connections loosened during shipment may cause damage or intermittent operation.

Other specific warnings and cautions are found where applicable and do not appear in this summary. See the *Elevator Industry Field Employees' Safety Handbook* for electrical equipment safety information on installation and service.

Electrical Safety

All wiring must be in accordance with the National Electrical Code and be consistent with all state and local codes.

Use the Proper Fuse

To avoid fire hazards, use only a fuse of the correct type, voltage, and current rating. See the job specific drawings sheet (Power Supplies) for fusing information.

Electric shocks can cause personal injury or loss of life. Circuit breakers, switches, and fuses may not disconnect all power to the equipment. Always refer to the wiring diagrams. Whether the AC supply is grounded or not, high voltage will be present at many points.

Printed Circuit Cards

Printed circuit boards may be damaged if removed or installed in the circuit while applying power. Before installation and/or removing printed circuit boards, secure all power.

Always store and ship printed circuit cards in separate static bags.

Electrical Safety*(continued)***Mainline Disconnect**

Unless otherwise directed, always Turn OFF, Lock, and Tag out the mainline disconnect to remove power from elevator equipment. Before proceeding, confirm that the equipment is de-energized with a volt meter. Refer to the *Vertical Express Employees' Safety and Accident Prevention Program Manual* for the required procedure.

Test Equipment Safety

Always refer to manufacturers' instruction book for proper test equipment operation and adjustments.

Megger or buzzer-type continuity testers can damage electronic components. Connection of devices such as voltmeters on certain low level analog circuits may degrade electronic system performance. Always use a voltmeter with a minimum impedance of 1M Ohm/Volt. A digital voltmeter is recommended.

When Power Is On

To avoid personal injury, do not touch exposed electrical connections or components while power is ON.

Mechanical Safety

See the *Elevator Industry Field Employees' Safety Handbook* for mechanical equipment safety information on installation and service.

Static Protection Guidelines

IMPORTANT!

Read this page before working with electronic circuit boards.

Elevator control systems use a number of electronic cards to control various functions of the elevator. These cards have components that are extremely sensitive to static electricity and are susceptible to damage by static discharge.

Immediate and long-term operation of an electronic-based system depends upon the proper handling and shipping of its cards. For this reason, the factory bases warranty decisions on the guidelines below.

Handling

- Cards shipped from the factory in separate static bags must remain in the bags until time for installation.
- Anti-static protection devices, such as wrist straps with ground wire, are required when handling circuit boards.
- Cards must not be placed on any surface without adequate static protection.
- Only handle circuit cards by their edges, and only after discharging personal static electricity to a grounding source. DO NOT touch the components or traces on the circuit card.
- Extra care must be taken when handling individual, discrete components such as EPROMS (which do not have circuit card traces and components for suppression).

Shipping

- Complete the included board discrepancy sheet.
- Any card returned to the factory must be packaged in a static bag designed for the card.
- Any card returned to the factory must be packaged in a shipping carton designed for the card.
- “Peanuts” and styrofoam are unacceptable packing materials.

Note: Refer to the Vertical Express Replacement Parts Catalog to order extra static bags and shipping cartons for each card.

Failure to adhere to the above guidelines will VOID the card warranty!

Arrival of Equipment

Receiving

Upon arrival of the equipment, inspect it for damage. Promptly report all visible damage to the carrier. All shipping damage claims must be filed with the carrier.

Storing

During storage in a warehouse or on the elevator job site, precautions should be taken to protect the equipment from dust, dirt, moisture, and temperature extremes.

Revision Change Bars

Each revised page included in this manual will have a vertical line (change bar) to the left of the text that has been added or changed. The example at the left of this paragraph shows the size and position of the revision change bar.

This page
intentionally
left blank.

Application

Overview

The sheave brake fulfills the safety code requirements for Ascending Car Overspeed Protection and Protection Against Unintended Car Movement. This brake will decelerate the car from the governor switch tripping speed with an empty car in the UP direction.

The sheave brake can also stop an empty car or a car loaded with 125% of capacity within 48 inches, when movement of the car is detected with the hoistway door not in the locked position, and the car door not in the closed position.

This brake covers all duties of the GD-2 Machines with 6 5/8-inch ropes (maximum), and all GD-1 Machines. On some GD-1 and GD-2 applications (with limited clearance) a sheave brake will not be able to be used. Consult the layout for specifics on installation.

With different brackets, the sheave brake is used on RH or LH Overhead and Basement Machines.



Do not move the car or counterweight rails if the hoistway was not properly constructed. Some basement applications may not have clearance between the cab and sheave brake if the rails or the hoistway are not set up according to the layout.

Specifications

- Maximum full load mass:
GD-1=19,000lbs. (8618kg)
GD-2=24,000lbs. (10,866kg)
- Maximum rated speed: 500 fpm (2.54m/s)
- Maximum tripping speed: 563 fpm (2.86m/s)
- Coil voltage: 140 vdc
- Resistance: 28 ohms
- Current: 4.5amps

Required Tools

- Test Weights, 125% Capacity Load
- TorqueWrench, 150ft. lbs.
- 24 mm Socket
- Shim Stock, Various Sizes
- 5 mm Hex Wrench
- 8 mm Hex Wrench
- 12 mm Hex Wrench
- 8 mm Combination Wrench
- Two - 17 mm Combination Wrench
- Two - 24 mm Combination Wrench
- 1 1/2" Open-End Wrench
- 9/16" Hex Wrench
- Nylon Hoisting Sling (2')
- Retainer Ring Pliers
- Screwdriver (Phillips)

Operation

Emergency Brake

If the emergency brake is dropped in an emergency situation (car overspeed, unintended car movement or redundancy check failure), a manual reset is required to put the car back in service.

Note: The emergency brake will not be lifted again, and the car will remain shut down until manually reset.

The car and the emergency brake are reset when all of the following conditions are met:

- The governor switch is reset.
- The car is in the door zone or the doors are closed.
- The brake lift switch (if applicable) indicates the normal brake is not lifted.
- The sheave brake lift switch indicates the sheave brake is not lifted.
- The car panel test (machine room) inspection switch is moved from Auto to Insp (all other inspection switches must be in the Auto position).

Ascending Car Overspeed Protection

Anytime the governor overspeed switch is tripped, the following events occur:

- With the car ascending or descending, the emergency brake is dropped.
- The safety string opens, which will turn off the drive and drop the normal brake.
- The car performs an emergency stop, a shutdown, and the doors are not allowed to open.
- Faults are logged by the controller indicating the safety string has opened during a run, and the emergency brake has been dropped.
- The car remains shutdown until manually reset.

Unintended Car Movement Protection

The unintended car movement protection is activated when the following events occur:

- If the car is not on inspection and the normal brake fails to hold the car at a floor (detected by the motor encoder), the drive activates and the car relevels.
- If the drive is not allowed to activate (open safety string) or if the drive fails to hold the car in the door zone, the emergency brake is dropped, the car is shut down, and the doors are disabled.

Notes:

- The emergency brake is adjusted to ensure the car stops within 48" of the floor. See A17.1.
- Faults are logged by the controller indicating a failed normal brake.
- The car remains shutdown until manually reset.
- During normal service (such as automatic, tenant security, emergency power recall) when no attendant is operating the car, the car relevels if the drive is allowed to activate.

Note: If this releveling operation occurs three times at the same floor, the emergency brake is dropped to hold the car level at the floor and then the car is shutdown.

Unintended Car Movement Protection

(continued)

- The unintended car movement protection is activated when the emergency brake is dropped, as long as the car remains in the door zone.
- If the emergency brake fails to hold the car at the floor (detected by the motor encoder), the emergency brake and normal brake are lifted and the car is run to the top floor.

Notes:

- When the car stops at the top floor, both the normal brake and the emergency brake are dropped, the car is shutdown, and the doors are disabled.
- Faults are logged by the controller indicating a failed normal brake and a failed emergency brake.
- The car remains shutdown until manually reset.
- During special operation (such as independent service, Phase 2 Fire Service) when an attendant is in control of the car, the car relevels if the drive is allowed to activate.

Notes:

- The car continues to relevel each time unintended car movement is detected until the special operation is de-activated.
- The emergency brake is dropped only if the car leaves the door zone with the doors open.
- As long as the car is in the door zone, the doors will be allowed to open.

Emergency Brake Operation

The A17.1–2000 code requires redundant devices be used to prevent a single failure of a device from rendering a critical circuit ineffective. These redundant devices must be checked (from a landing on automatic operation) prior to each start of the elevator. See Section 2.26.9.3 and 2.26.9.4.

The emergency brake is dropped and the car is shutdown if a redundancy check failure indicates a possible problem controlling the emergency brake. Faults are logged by the controller showing the redundancy check failure.

Note: The emergency brake will be dropped for situations other than those outlined in A17.1–2000 Section 2.19.

Sheave Brake Operation

Normal Operation

- At the start of a run, the sheave brake is lifted an adjustable time before the normal brake is lifted (this ensures that the emergency brake is lifted from a stationary braking surface). See A17.1.2.
- When pre-torque is started (if pre-torque is functioning), the sheave brake is lifted to avoid delaying the start of a run.
- Once the sheave brake is lifted, it will stay lifted after the car stops.
- The normal brake is dropped (until an adjustable time has expired) to ensure that the emergency brake is dropped on a stationary braking surface. See A17.1.
- If the drop delay time does not expire before the next run begins, the sheave brake remains lifted and, when the car stops, the drop delay time will start over.

Sheave Brake Operation

(continued)

- Because the sheave brake will sometimes be lifted when the drive is not energized, a separate brake contactor is required.

Notes:

- The contacts from this brake contactor are not wired in series with MC contacts.
- Normal operation is not intended to have the sheave brake lifted and dropped on each run.

Inspection Operation

- The sheave brake is lifted and dropped at the same time as the normal brake.
- If the sheave brake is previously lifted when inspection operation is activated, the sheave brake is dropped.
- The sheave brake is dropped any time the safety string is opened.

Note: The TAC-50 sheave brake is dropped if the car speed exceeds 15 fpm above IVE parameter (inspection speed).

GD-1 Sheave Brake Installation

The sheave brake is shipped separately and must be assembled to the machine in the field.



WARNING

The sheave brake spring is compressed from the factory. Do not remove the temporary shipping fasteners until instructed.

1. Turn OFF, Lock, and Tag out the mainline disconnect.
2. Clean the drive sheave brake surface of any oil, dirt and paint.
3. Install the hoist ropes.
4. Verify that the brake mounting bracket (installed at the factory) is parallel to the drive sheave to within 1/32 inch. Shim as required. See Figure 1.

Note: If shims are required, use a 12 mm hex wrench to access the center bolt in the brake mounting bracket through the hole in the drive sheave.

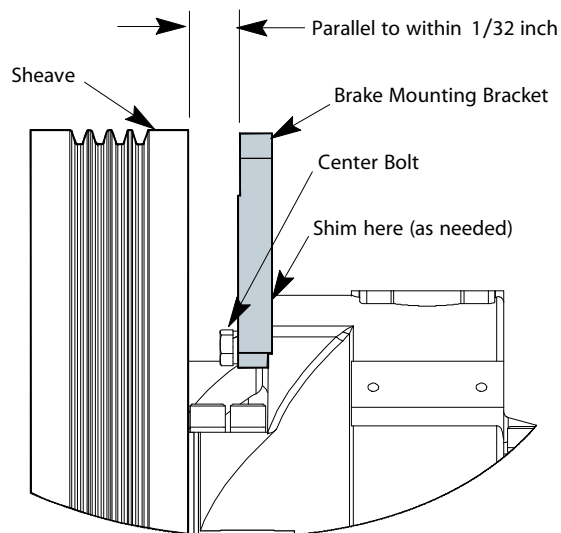

Figure 1 - Brake Shoe and Sheave Alignment

GD-1 Sheave Brake Installation

(continued)

5. Measure the distance from the sheave to the machined surface of the brake mounting bracket. Determine and record the quantity of mounting bracket shims that are required. See Figure 2 and Table 1.

Note: Brake mounting bracket shims are supplied by the factory.

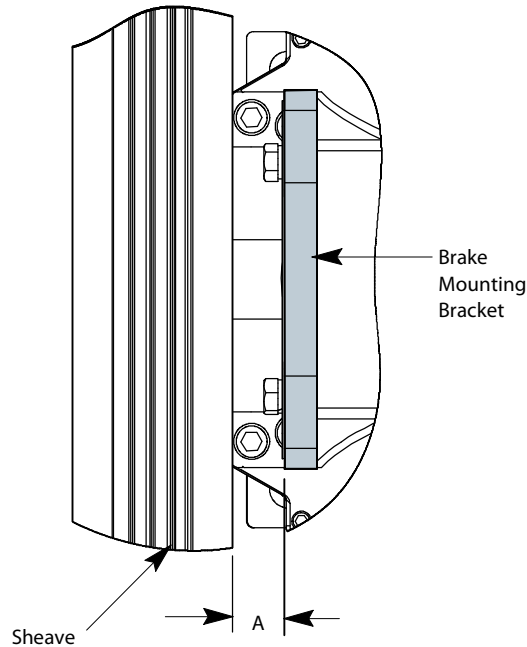

Figure 2 - Brake Mounting Bracket to Sheave Dimension

Dimension A (from Figure 2)	Shim Quantity
1 15/16" to 13 1/32"	1
>1 31/32" to 2"	2
>2" to 2 1/32"	3

Table 1 - Brake Mounting Bracket Shimming

6. Locate the box containing the sheave brake.
7. Remove the sheave brake from the shipping container.
8. Use a choker arrangement to install the hoisting strap around the coil. See Figure 3 on page 13.
9. Remove the brake shoe (located on the name plate side of the sheave brake).

Note: The brake shoe located opposite the name plate side is to remain installed.

GD-1 Sheave Brake Installation

(continued)

10. Remove the following items from the sheave brake. See Figure 3.

- M16 self-locking nut
- Wave spring and washer
- M5 x 10 mm screw
- Brake shoe assembly
- Brake shoe guide

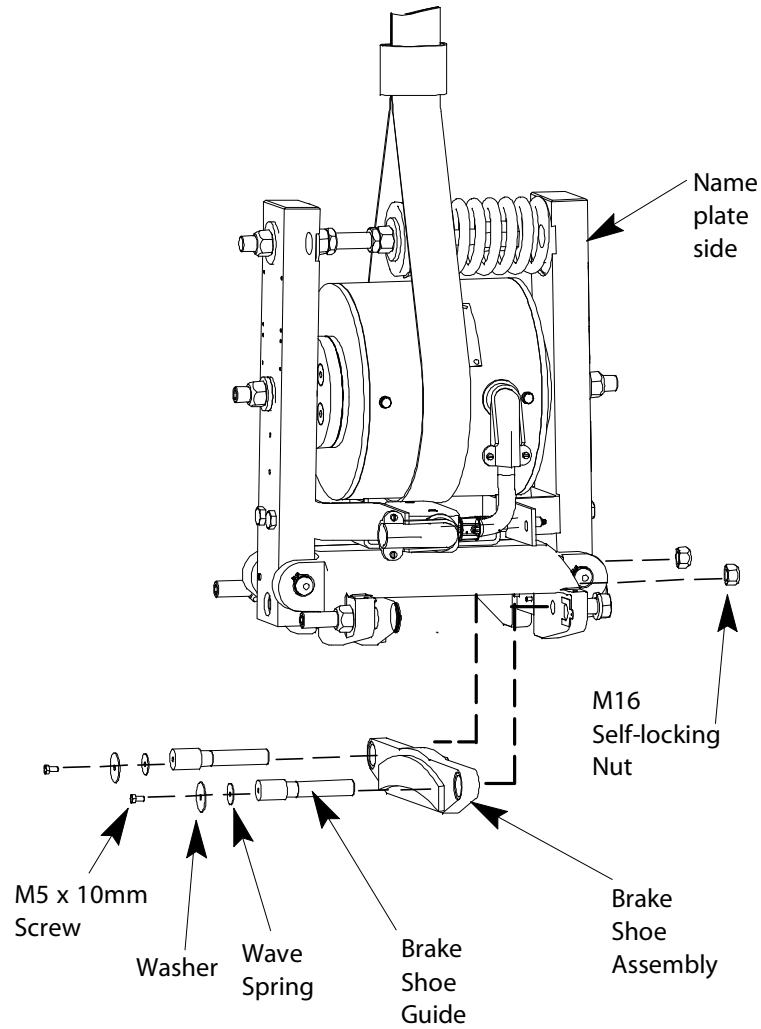

Figure 3 - Brake Shoe Removal

GD-1 Sheave Brake Installation

(continued)

11. Use two (2) M16 x 45 mm long bolts and M16 lockwashers to install the sheave brake to the sheave brake mounting bracket (installed at the factory). See Figure 4.

Note: Do not tighten the bolts.

12. Insert the quantity of mounting bracket shims (recorded in a previous step using Table 1).

13. Torque the bolts to 120 ft-lbs.

14. Remove the nylon hoisting sling.

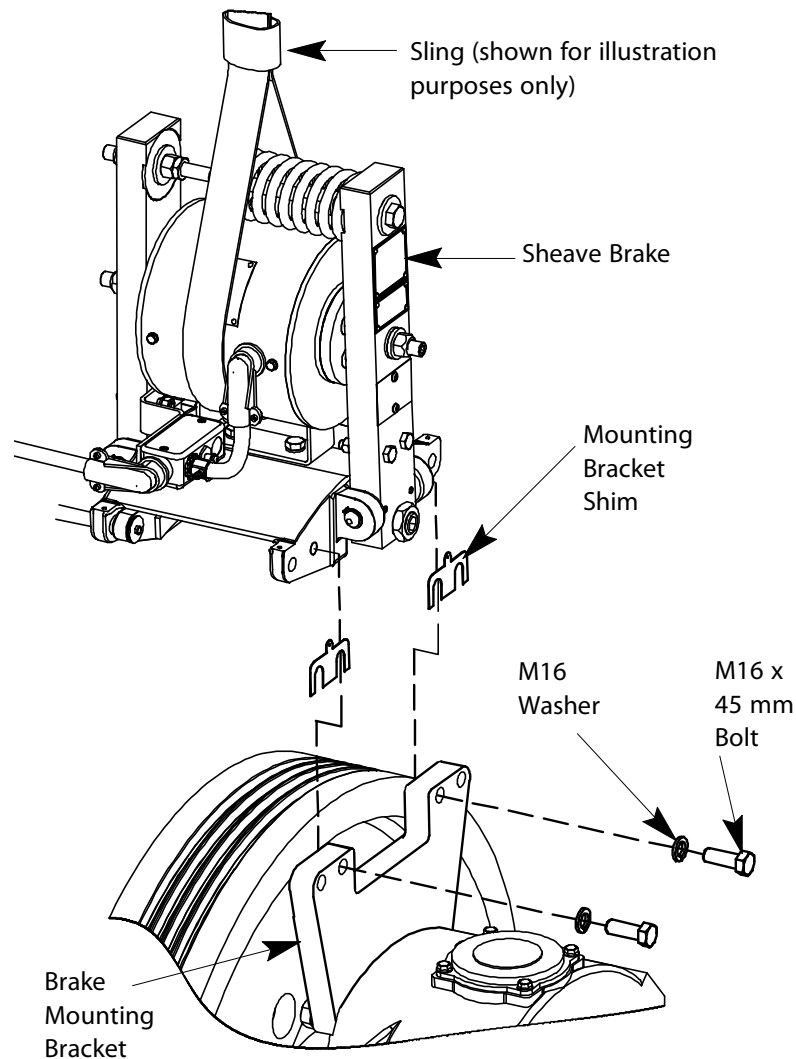

Figure 4 - Hoisting the Sheave Brake

GD-2 Sheave Brake and Brake Mount

The sheave brake is shipped separately and must be assembled to the machine in the field.



WARNING

The sheave brake spring is compressed from the factory. Do not remove the temporary shipping fasteners until instructed.

1. Turn OFF, Lock, and Tag out the mainline disconnect.
2. Clean the drive sheave brake surface of any oil, dirt and paint.
3. Install the hoist ropes.
4. Use four (4) M16 x 60 mm bolts and four (4) M16 lockwashers to install the brake mount to the machine. See Figure 8.

Note: Do not tighten the bolts.

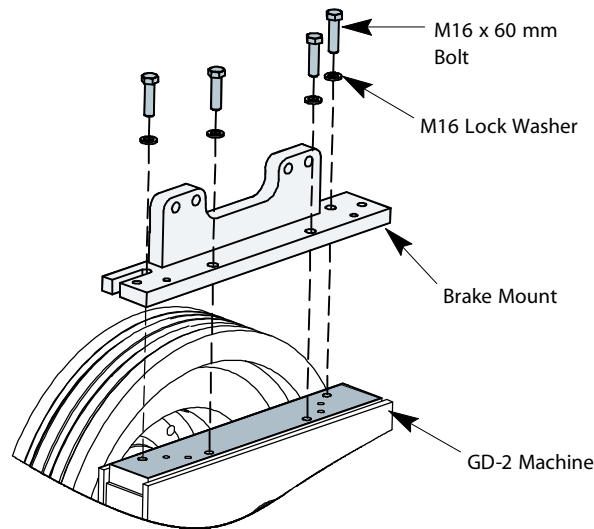

Figure 5 - Brake Mount Installation for Overhead Machine

5. An angled brake mount is supplied for some basement applications. To install an angled brake mount:
 - a. Place the M16 x 60 mm bolt at the slot location.
 - b. Slide the brake mount under the bolt head and lockwasher. See Figure 9.
 - c. Install the three (3) remaining bolts and lockwashers.

GD-2 Sheave Brake and Brake Mount

(continued)

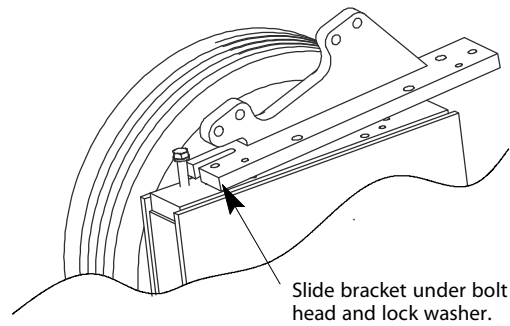

Figure 6 - Brake Mount Installation for Basement Machine

6. Verify that the brake mount is parallel to the drive sheave—within 1/32 inch. Adjust the mounting bracket and shim as required. See Figure 10.
7. Tighten the bolts to 120 ft-lbs.

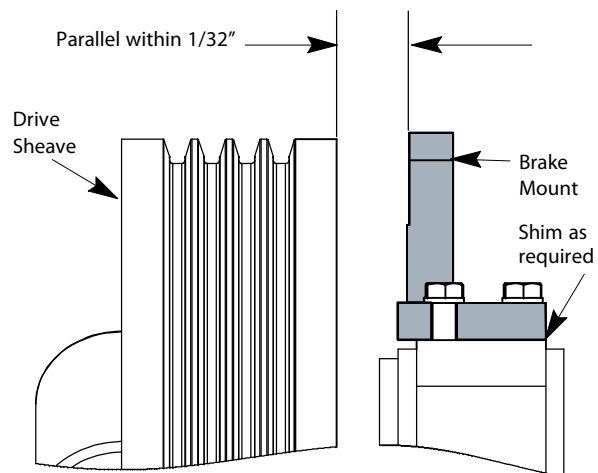

Figure 7 - Sheave and Brake Mount Parallel Surfaces

8. Measure the distance from the sheave to the machined surface of the brake mounting bracket. Determine and record the quantity of mounting bracket shims that are required. See Figure 8 and Table 2.

Note: Brake mounting bracket shims are supplied by the factory.

GD-2 Sheave Brake and Brake Mount

(continued)

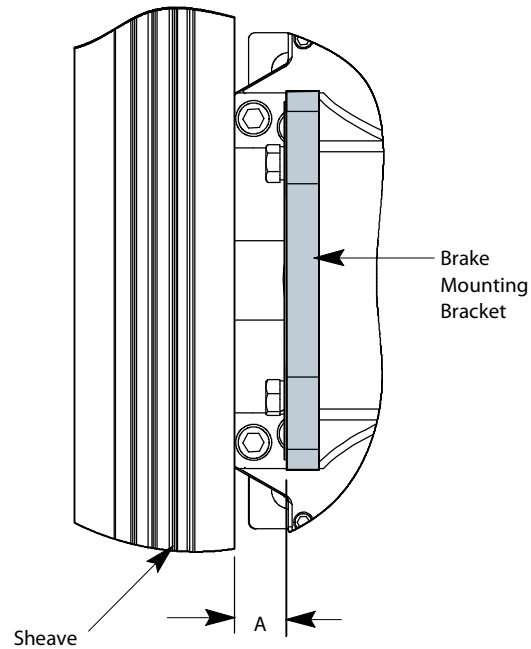

Figure 8 - Brake Mounting Bracket to Sheave Dimension

Dimension A (from Figure 2)	Shim Quantity
1 15/16" to 1 31/32"	1
>1 31/32" to 2"	2
>2" to 2 1/32"	3

Table 2 - Brake Mounting Bracket Shimming

9. Locate the box containing the sheave brake.
 10. Remove the sheave brake from the shipping container.
 11. Use a choker arrangement to install the hoisting strap around the coil. See Figure 9.
 12. Remove the brake shoe (located on the name plate side of the sheave brake).
- Note:** The brake shoe located opposite the name plate side is to remain installed.

GD-2 Sheave Brake and Brake Mount

(continued)

13. Remove the following items from the sheave brake. See Figure 9.

- M16 self-locking nut
- Wave spring and washer
- M5 x 10 mm screw
- Brake shoe assembly
- Brake shoe guide

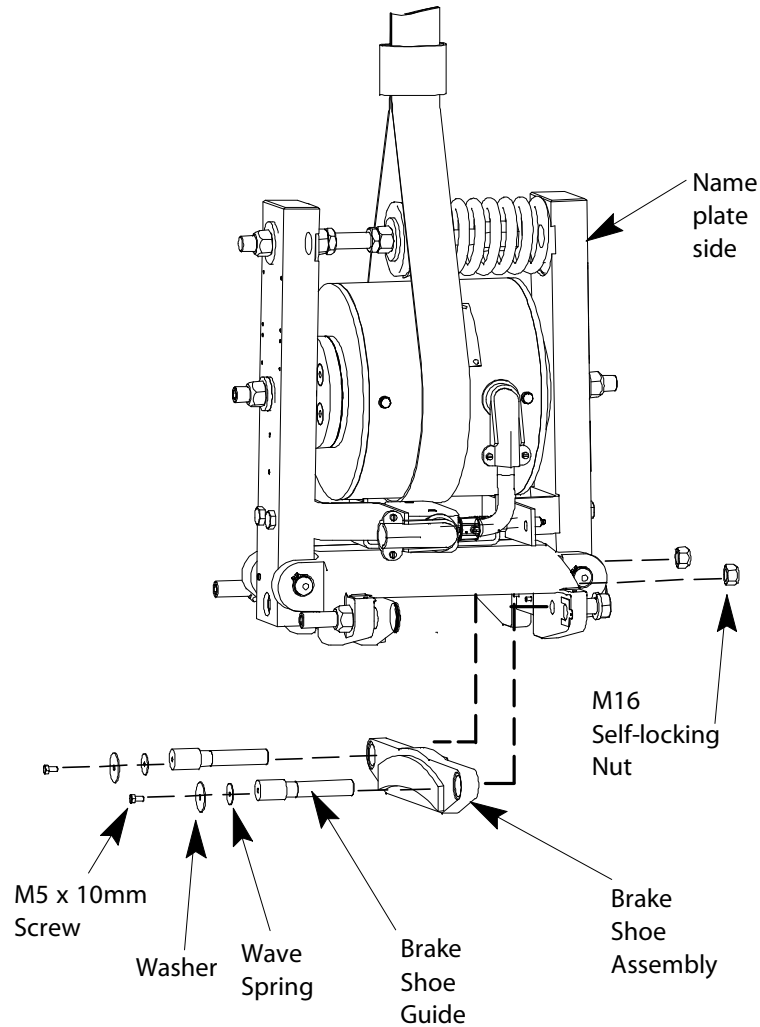

Figure 9 - Brake Shoe Removal

GD-2 Sheave Brake Installation

(continued)

14. Use two (2) M16 x 45 mm long bolts and M16 lockwashers to install the sheave brake to the sheave brake mounting bracket (installed at the factory). See Figure 10.

Note: Do not tighten the bolts.

15. Insert the quantity of mounting bracket shims (recorded in a previous step using Table 1).

16. Torque the bolts to 120 ft-lbs.

17. Remove the nylon hoisting sling.

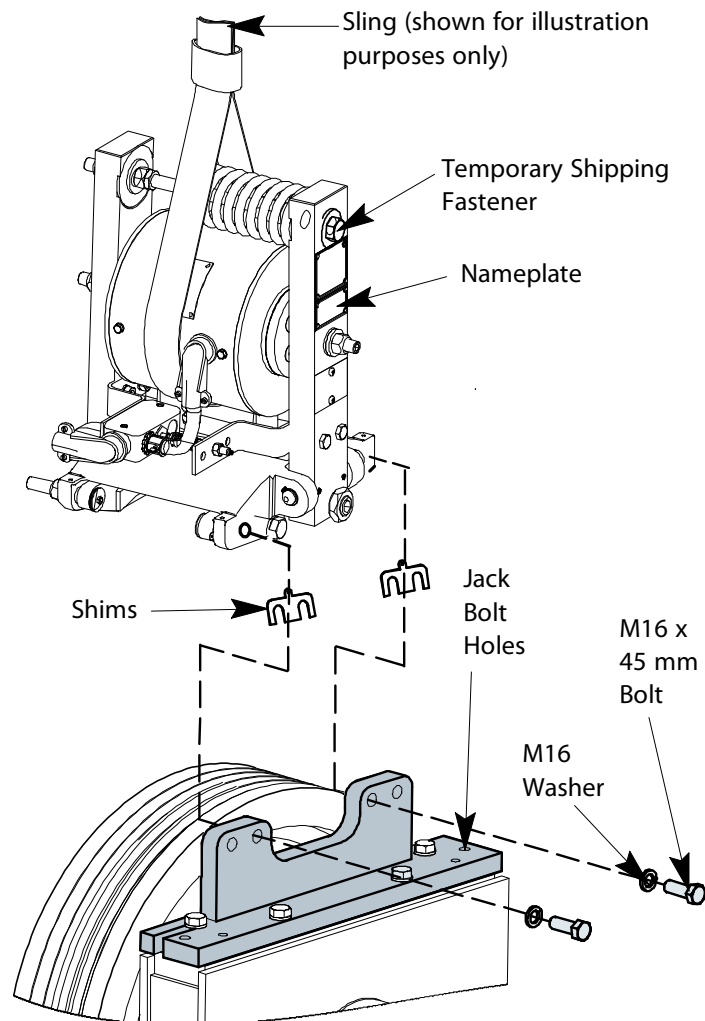

Figure 10 - Sheave Brake Mounting

Brake Shoe Installation

1. Slide the brake shoe assembly between the caliper and the sheave. See Figure 11.
2. Install the brake shoe guide through the brake shoe and also the brake mounting bracket.
3. While holding the guide pin with an 8 mm hex wrench, install the M16 self-locking nut and lightly tighten. See Figure 12.

Note: If there is a problem installing the brake shoe guide on a GD-2 Machine with a 36" sheave:

- a. Loosen four (4) M16 x 60 mm brake mount mounting bolts.
- b. Use an M16 x 45mm bolt to jack the brake mount up through the jack bolt hole. See Figure 11.
- c. Realign the mount to the drive sheave. See Steps 5 and 6 in the *GD-2 Brake Mount to Sheave Alignment* procedure.

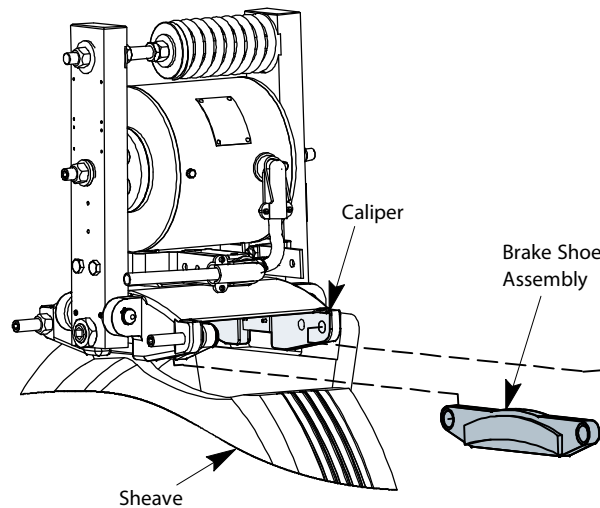

Figure 11 - Brake Shoe Installation

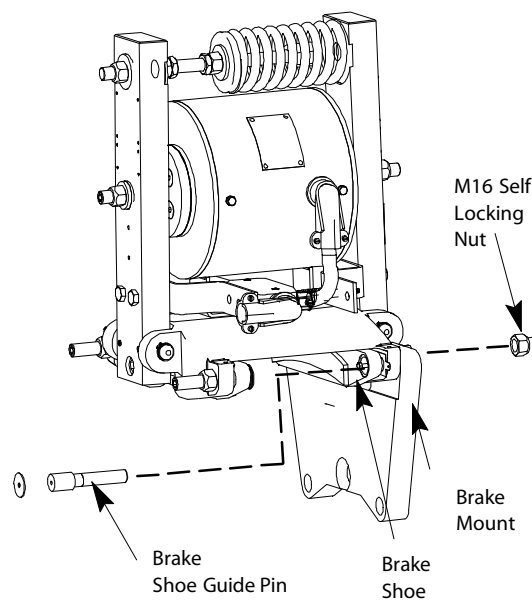

Figure 12 - Brake Shoe Mounting

Brake Shoe Installation

(continued)

4. Use a 1 1/2" wrench to loosen the brake shoe adjusting nut. See Figure 13.
5. Insert a 9/16" hex wrench into the brake shoe adjusting screw, and turn until the brake shoe just contacts the sheave.
6. With the brake shoe against the face of the sheave, verify that the guide pin extends 1/8" beyond the shoe face. See Figure 14 on page 22.

Notes:

- If the guide pin extends more than 3/16" beyond the shoe face, contact Memphis Field Engineering for instructions.
 - If the guide pin extends less than 1/8" beyond the shoe face, hold the guide pin with a 8 mm hex wrench and loosen the self-locking nut.
7. Insert the appropriate number of shims between the caliper and the guide pins to obtain 1/8". See Figure 14 on page 22.

Note: The shims are shipped taped to the sheave brake switch bracket.

8. Install the wave spring, washer, and the M5 x 10 mm screw. See Figure 15 on page 22.
9. Tighten the self-locking nut.
10. Repeat Steps 3 through 7 for the opposite side of the brake shoe.

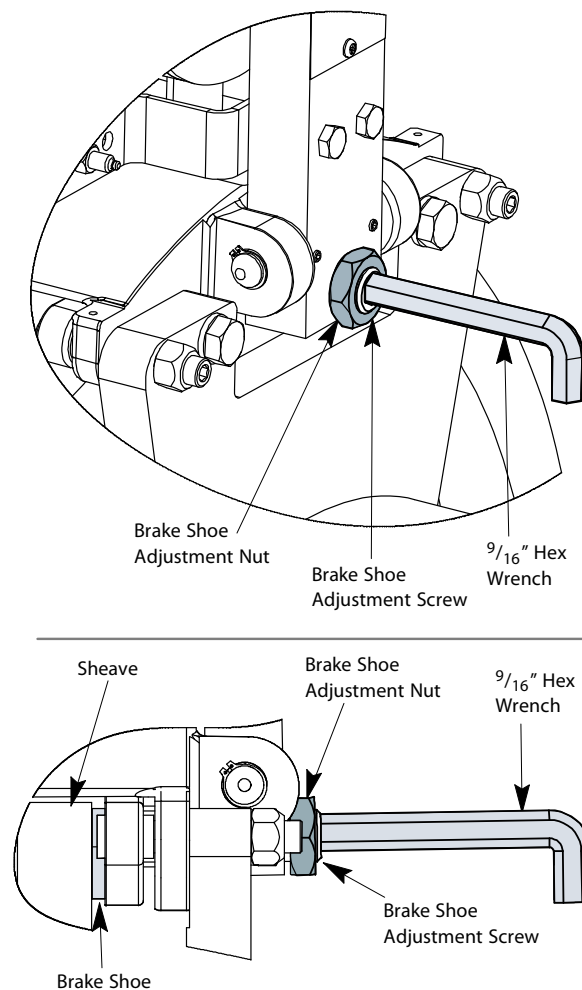
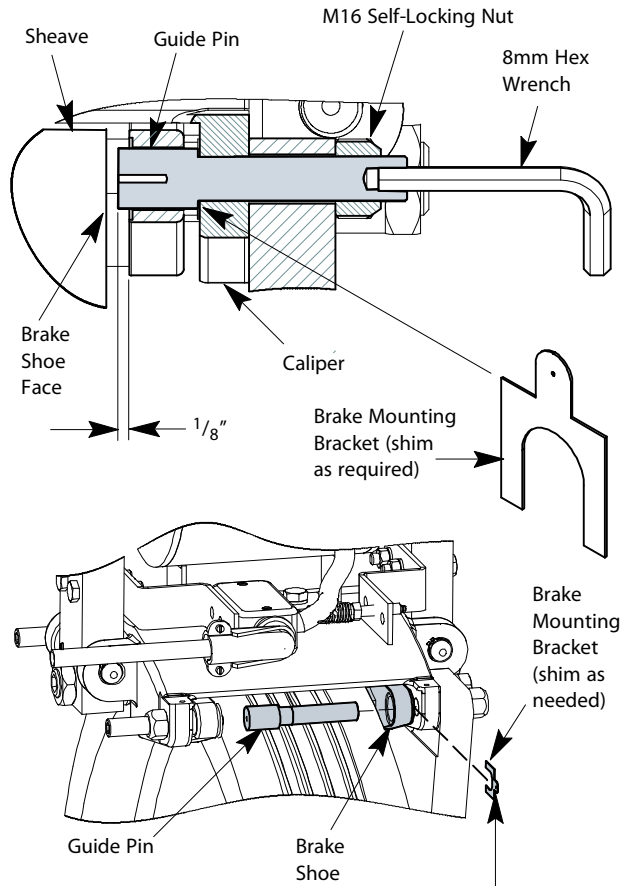

Figure 13 - Brake Pad Adjustment

Brake Shoe Installation
(continued)



NOTE: Shims shipped taped to brake switch bracket

Figure 14 - Guide Pin Clearance

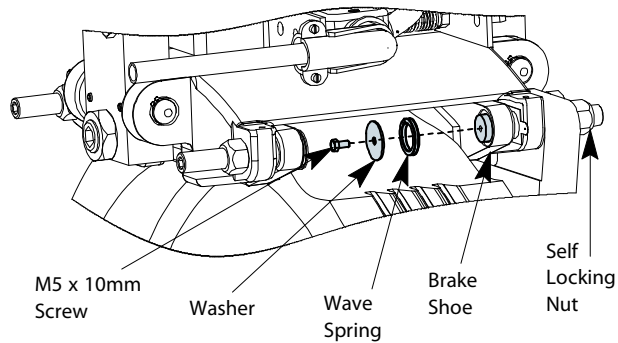

Figure 15 - Brake Shoe Mounting

Sheave Brake Switch Relocation

The sheave brake switch is installed at the factory. Use the following procedure if the sheave brake switch is to be located on the opposite side.

Note: Twenty-five (25) inches of flex-conduit is furnished with the sheave brake. This material allows the sheave brake switch to be moved to the opposite side.

1. Remove the two (2) M10 x 60 screws and the two (2) M10 nuts attaching the sheave brake switch to the sheave brake assembly.
2. Remove the two (2) M10 x 60 screws and the two (2) M10 nuts attaching the sheave brake switch actuator to the sheave brake assembly.
3. Use four (4) M10 x 60 screws and four (4) M10 nuts to reassemble the sheave brake switch and actuator on the opposite side of the sheave brake. See Figure 16.

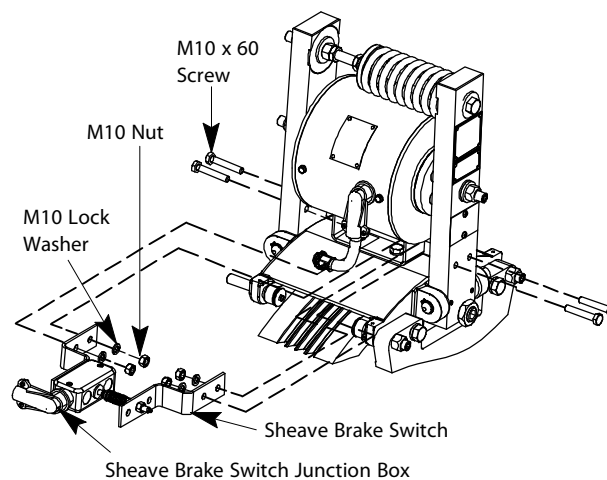

Figure 16 - Sheave Brake Switch Relocation

Wiring

Sheave Brake Coil Wiring

1. Pipe conduit from the controller to the switch junction box.
 2. Cut—to length—the sheave brake coil flex-conduit.
 3. Connect the flex conduit to the switch junction box.
 4. Pull four (4) 14 gauge wires from the controller to the switch junction box.
- Note:** Two of the wires will be for the sheave brake coil, and two wires will be for the sheave brake switch.
5. Label two of the wires as SBK+ and SBK-, and then connect them to the coil wires.
 6. Label the remaining two wires as RG5 and RG7, and then connect them to the sheave brake switch.

Adjustments

Spring Adjustment

1. Verify the distance between the outside of the brake levers. The top distance is $12 \frac{5}{8}'' \pm \frac{1}{16}''$, and the spring length is $5 \frac{7}{8}'' \pm \frac{1}{16}''$. See Figure 17.
 - The spring length and the distance between the arms is set at the factory—but must be checked—and may require adjustment.
 - The spring is recessed into one sheave brake lever. Measurements must be taken at the bottom of the spring recess.
 - a. If the distance between the sheave brake levers is not $12 \frac{5}{8}'' \pm \frac{1}{16}''$:
 - Verify that the distance from the sheave brake lever to the end of the rod dimension is $1 \frac{1}{2}''$. Correct (if necessary) by adjusting the threaded rod. See Figure 18 on page 24.
 - If the sheave brake lever to the end of the rod dimension is correct ($1 \frac{1}{2}''$), tighten the temporary shipping fasteners to obtain the $12 \frac{5}{8}''$ dimension.
 - b. If the spring length is not $5 \frac{7}{8}'' \pm \frac{1}{16}''$:
 - Loosen the spring jamb nut (M16).
 - Use the spring adjustment nut (M16) to adjust the spring length to $5 \frac{7}{8}''$.
 - Retighten the spring jamb nut (M16).

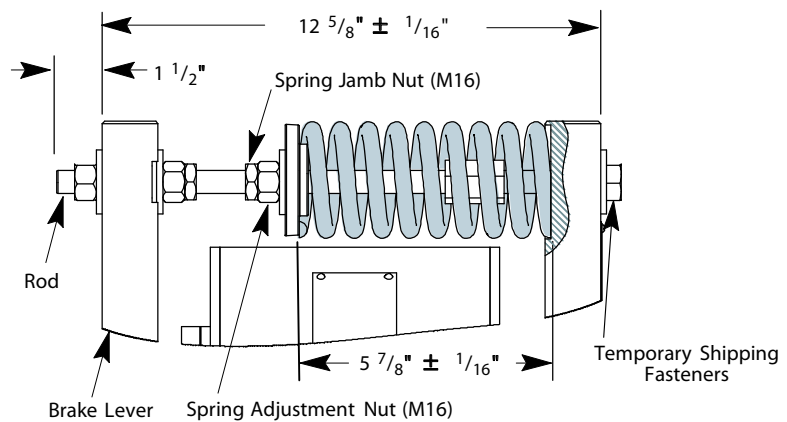

Figure 17 - Spring Adjustment

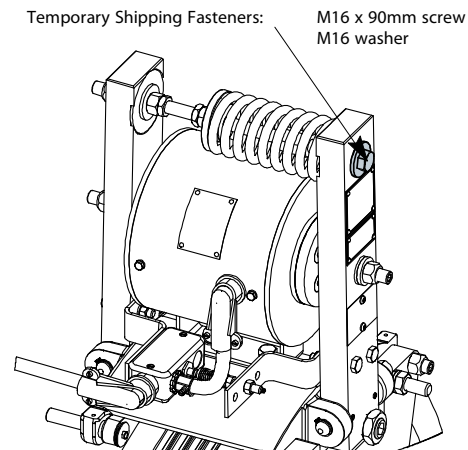

Figure 18 - Temporary Shipping Fasteners

Armature Adjustment

The armature is adjusted in the factory but must be verified on the job site.

1. Push both of the solenoid armatures into the solenoid housing as far as they will go, and hold them into place.
2. Tighten the armature adjustment nut until the male spherical washer just contacts the sheave brake lever. See Figure 19.

Note: If the solenoid armatures do not touch the face of the solenoid housing, loosen the armature adjustment nut until the armature just contacts the housing. See Figure 19.

3. Repeat Step 1 and Step 2 for the other brake lever.

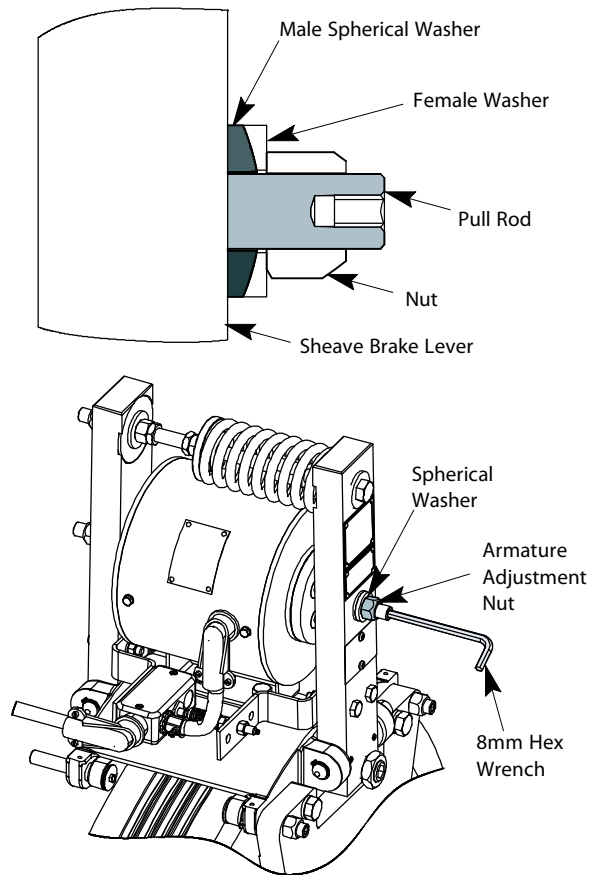

Figure 19 - Armature Adjustment

Electrical Adjustments

All controller connections, sheave brake coil, and sheave brake lift switch wiring must be completed before any electrical adjustments can be made.

1. Turn ON the mainline disconnect.
2. Position the TAC50 Controller panel AUTO/INSP switch to INSP.
3. Turn ON the CB1, I/O, and CPU switches.
4. In the IMS Remote FAST, type STM (to put the controller in setup mode), and then set IVE=0.
Note: The sheave should not rotate on Inspection Run with these settings.
5. Clear any 200 Series sheave brake faults. See the *Sheave Brake Faults* in the *Troubleshooting* section.
6. Attempt an Inspection Run to verify that the drive sheave does not rotate.
7. While attempting to run on Inspection, verify the following:
 - a. Input GTS and Outputs BKE, UMD, RGC1, and RGC2 are active.
 - b. Output EBH activates shortly after the start of the Inspection run.
 - c. Inputs GTSM, GTSXM, and SBKM are inactive.
 - d. Relays and their normally opened contacts GTS, GTSX, RGC1, RGC2, and EBH, after a delay, are energized.
 - e. Contactor SBK and its normally opened contacts are energized.
8. Stop the Inspection run, and verify that Output BKE is inactive. Before proceeding, correct any of the devices in the above steps to their proper states.
9. Place a clamp on the amp meter around either the SBK+ or SBK– wire with the scale set for dc amps.
10. Make an Inspection run with IVE=0, and verify that the pick current is 4.5 amperes and 1.5 amperes for hold. The hold currents are set at the factory but must be verified and adjusted at the job site.
 - If the hold current is not 1.5 amperes, adjust the RSBR resistor.
 - The pick current is not adjustable, but should be 4.5 amperes. Call Memphis Field Engineering if the current is greater than 4.8 or less than 4.3 amperes.

Brake Shoe Adjustment

Note: Temporary shipping fasteners should remain installed until Step 9.

1. Remove the .010 inch feeler gauge from the nameplate side of the brake assembly. See Figure 20.

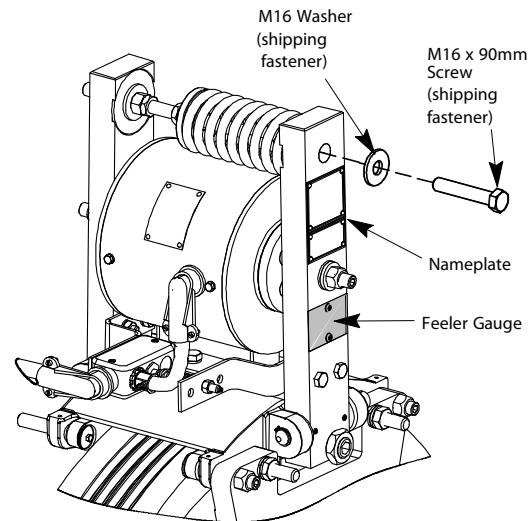

Figure 20 - Feeler Gauge Location

2. Energize the sheave brake by attempting to run the car on Inspection.
 3. Use a 1 1/2 inch combination wrench to loosen the brake shoe adjustment locknut.
 4. Insert a 9/16 inch hex wrench into the brake shoe adjusting screw.
 5. Place a .010 inch feeler gauge between the sheave and brake pad.
 6. Turn the wrench until the brake shoe just contacts the feeler gauge. See Figure 21 on page 28.
- Note:** The feeler gauge is used to adjust the clearance between the brake shoe and the sheave.
7. Hold the brake shoe adjusting screw in place and tighten the brake shoe adjustment locknut.
 8. Repeat Steps 3 through 7 on the remaining sheave brake shoe.
 9. Remove the shipping fastener, the M16 x 90 mm screw, and the M16 washer. See Figure 21 on page 28.

Note: The sheave brake should still be energized.



WARNING

Do not remove the shipping fastener by hand. Use a wrench when removing or installing the shipping fasteners.

10. Stop the Inspection Run by de-energizing the sheave brake.
11. Measure the spring length.
 - If the spring length is greater than 6 9/16 inches but less than 6 13/16 inches, loosen the spring jamb nut (M16) and use the spring adjustment nut (M16) to adjust the spring length to 6 9/16 inches. See Figure 22 on page 28.
 - If the spring length is more than 6 13/16 inches, call Memphis Field Engineering.

Brake Shoe Adjustment

(continued)

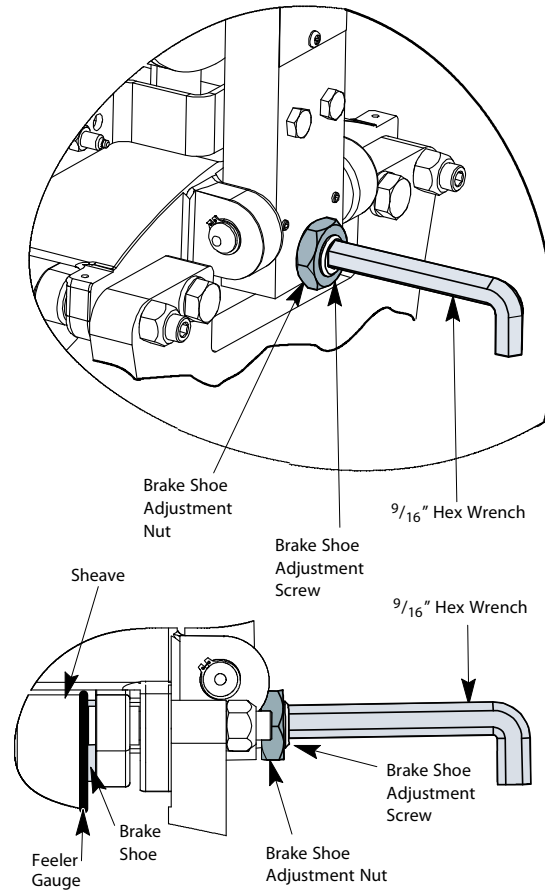

Figure 21 - Brake Pad Adjustment

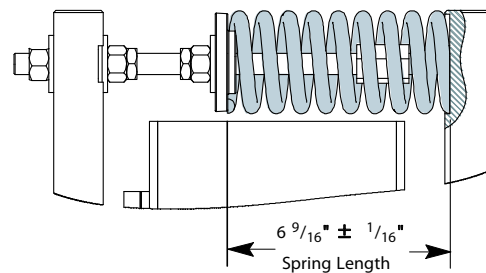

Figure 22 - Spring Adjustment (de-energized state)

12. Energize the sheave brake with an Inspection Run.
13. Use a .010 inch feeler gauge to check the gap between the sheave and the brake shoe.
 - If the gap is .010 inches, the installation is complete.
 - If the gap is not .010 inches:
 - a. Energize the sheave brake with an Inspection Run.
 - b. Reinstall the shipping fasteners.
 - c. Repeat Steps 3 through 13.

Maintenance

Sheave Brake

Routine maintenance of the sheave brake must be performed. Parts showing signs of damage or wear must be replaced with approved parts only.

The following checks must be performed:

- Clean the sides of the drive sheave rim.
- Verify that pad material is a minimum of 1/8" thick.
- Check for wear or loose bushings in the caliper.
- Verify that the lift switch operation is smooth.
- Perform annual tear down and inspection of the solenoid coil, the armatures, and the sleeve.

Troubleshooting

Sheave Brake Faults

If the brake is not properly picking or dropping, it is due to improper adjustment or maintenance.

Car Fault Number	Description
219	A17/B44 ONLY. Unintended Motion Brake Test Fault – The Unintended Motion Brake Test failed.
220	A17/B44 ONLY. Unintended Motion Device Failed Fault – Unintended Motion was detected.
221	A17/B44 ONLY. Unintended Motion Device Dropped Fault – The Sheave Brake Failed.
222	A17/B44 ONLY. Sheave Brake Contactor Failed Fault 1 – The sheave brake contactor monitoring input (SBKM) is low when the BKE output used to control the sheave brake is low.
223	A17/B44 ONLY. Sheave Brake Contactor Failed Fault 2 – The sheave brake contactor monitoring input (SBKM) is high when the BKE output used to control the sheave brake is high.
224	A17/B44 ONLY. Sheave Brake Lift Switch Failed Fault 1 – The GTS input is low when the BKE output used to control the sheave brake is high.
225	A17/B44 ONLY. Sheave Brake Lift Switch Failed Fault 2 – The GTS input is high when the BKE output used to control the sheave brake is low.
Note: For complete descriptions, see the IMS Help Files or the TAC50 Manual.	

Sheave Brake I/O

Designator	Name of I/O	Input/Output
GTS	Rope Gripper Trip Switch	Input
GTSM	Rope Gripper Trip Switch Monitor	Input
GTSXM	Rope Gripper Trip Switch Auxiliary Monitor	Input
SBKM	Sheave Brake Contactor Monitor	Input
UMD	Unintended Motion Device	Output
EBH	Emergency Brake Hold	Output
RGC1	Rope Gripper Control 1	Output
RGC2	Rope Gripper Control 2	Output
BKE	Emergency Brake Output	Output

Troubleshooting

(continued)

Sheave Brake Relays and Contacts

MNE	Function	Coil	Coil Voltage	Normally Closed Contacts	Normally Closed Voltage	Normally Open Contacts	Normally Open Voltage
GTS	Rope Gripper Trip Switch	A1-A2	110vac	22-21	24vdc	44-43	128vdc
GTSX	Rope Gripper Trip Switch Auxiliary Monitor	A1-A2	110vac	22-21	24vdc	44-43	128vdc
RGC1	Rope Gripper Control 1	A1-A2	24vdc	13-14 21-22	128vdc 24vdc	44-43	110vdc
RGC2	Rope Gripper Control 2	A1-A2	24vdc	13-14 22-21	128vdc 24vdc	44-43	110vdc
EHB	Emergency Brake Hold	A1-A2	24vdc	21-22 31-31	128vdc	—	—

Sheave Brake Contactors

MNE	Function	Coil	Coil Voltage	Normally Closed Contacts	Normally Closed Voltage
SBK	Sheave Brake Contactor Monitor	A1-A2	110vac	1-2 3-4 5-6	3 Phase ac
SBK	Sheave Brake Auxiliary Contactors	—	24vdc	41 42	—

Technical Information

TAC50 Sheave Brake Adjustments

Adj	Unit	Range	Default	Definition
SBD	sec	1200-3600	3600	Sheave Brake Drop Delay Time – This sets the delay for dropping the sheave brake. The time is reset after each stop. Therefore, for this time to expire and cause the sheave brake to drop, the car must not make a run for the amount of time specified.
EBP	1/16 sec	0-80	4	Emergency Brake Pick Timer – Adjusts the time between when the emergency brake picks and when the normal brake picks. This time should be long enough to allow the emergency brake to be lifted completely before starting to lift the normal brake. The emergency brake must be lifted off of a stationary surface. If pre-torque is functioning, the emergency brake will start to pick when pre-torque starts (when the doors reach the DL6 limit). If pre-torque is not functioning, the emergency brake will not start to lift until the doors get fully closed. Then, after this delay, the normal brake will start to lift. Therefore, if pre-torque is not functioning, the start of a run will be delayed by this time.
DRS	—	—	—	Display Runtime Statistics-This parameter will display specific information pertaining to that individual car. See RRS and SAM commands.

Other Information

Mean = average

SDEV = deviation off average

Run Time Stats

Sample Time : days-h : m : s

MG runtime: 000 hours

MG starts: 00000

Miles run: 0000.0

car runs: 00000

Door cycles: 00000

Door revs: 00000

Door in use: days-h : m : s

Sheave Brake cycles: 00000

Sheave Brake in use: days-h : m : s

TIMING - Baseline Mean SDEV

Front door close: 4.81 0.12

Front door open: 3.56 0.00

One floor run: 5.81 0.50

TAC50 Sheave Brake Test Procedures

Ascending Car Overspeed Test

ASME A17.1 Section 2.19.3.2 (a) requires retarding the empty car in the UP direction up to 110% of the governor tripping speed.



Make certain that the following items have been done before proceeding with the safety test:

- All adjacent cars in the hoistway have been positioned at the bottom terminal floor and taken out of service.
 - The top of the car under test has been inspected and all loose objects have been removed.
 - The inside of the car under test has been inspected and all loose objects have been removed.
1. Place the empty car at the bottom terminal landing and the Auto/Inspect switch to Inspect with the doors OFF.
 2. Turn OFF the CPU, I/O, and CB1 Switches.
 3. Turn OFF, Lock, and Tag out the mainline disconnect.
 4. Remove Connector 3 from the brake regulator card and place a temporary jumper between pins 1 and 2.

Note: The jumper connection will allow the brake regulator card to output current to the machine brake during the sheave brake test.
 5. Replace Connector 3 to the brake regulator card.
 6. Connect a temporary jumper between V+ and UIN (this action will overspeed the car).

Note: Connecting V+ to UIN will cause the car to accelerate at the programmed acceleration rate to programmed test speed; removing the jumper from V+ to UIN will slow the car to contract speed.
 7. Connect Channel One of an oscilloscope to the DSP test point OUT 1 and AGND, and Channel Two to test point OUT 2 and AGND.
 8. Make the following oscilloscope adjustments:
 - a. Set each oscilloscope channel to 1v/div.
 - b. Set the time base to 2 sec/div.
 - c. Place the AC/GND/DC switches on both channels to the GND position, and both signal traces at the bottom of the oscilloscope display.
 - d. Place the AC/GND/DC switches to the DC position.
 9. Unlock and turn ON the mainline disconnect.
 10. Turn ON the CB1, I/O, and CPU Switches.
 11. In the Remote FAST, set parameter TPT1 = DV to output speed reference.
 12. Set TPT2 = CV to output speed feedback.
 13. Turn the AUTO/INSPECT Switch to Auto.

Ascending Car Overspeed Test

(continued)

Initiate the Ascending Car Overspeed Test

1. Enter the TST4 Command. The Remote FAST displays "Run OVERSPEED test? (Y/N)."
2. Enter "Y" to enable the test. The Remote FAST displays "Enter maximum overspeed allowed:"
3. Determine the maximum overspeed, take the switch trip speed from the governor nameplate and add 10% (e.g., a 350 fpm car will have a switch trip speed = 407 fpm, $407 \times 1.10 = 447.7$ or 448 fpm).
4. Enter 110% of the switch trip speed. The Remote FAST displays "Enter overspeed acceleration rate."
5. Enter the desired acceleration rate from the contract speed to the test speed. The Remote FAST displays "Enter car call to execute OVERSPEED test."

Note: The overspeed acceleration rate must be less than or equal to the programmed ACR value.

6. Place a car call to the top landing.
 7. After the car starts to run, use a non-conductive device to manually hold the BK1 and MC Contactors closed.
- Note:** The machine brake will be held open during the sheave brake test as long as the BK1 and MC Contactors are closed.
8. View the car speed on the oscilloscope and verify that once the governor speed switch opens the safety circuit, the car speed is retarding and reduces to buffer rated striking speed. If the car speed does not decelerate or the deceleration rate flattens and then starts to accelerate, abort the test by releasing the BK1 and MC Contactors.
 9. If the test was aborted by dropping the machine brake, verify that the drive sheave brake surface is clean and free of oil. Check the sheave brake spring adjustment and shoe-to-sheave-clearances in their respective sections of this manual.

10. Repeat Steps 14 through 17 until a successful test has been performed.

Note: Repeat this test at least three times to burnish the sheave brake shoe linings. This action improves the sheave brake shoe linings coefficient of friction.

The test has passed when:

- The car comes to a complete stop from the sheave brake alone
- or
- The counterweights strike their buffer(s) at less than or equal to their rated speed

11. Turn OFF the CPU, I/O, and CB1 Controller Switches.

12. Turn OFF, Lock, and Tag out the mainline disconnect.

13. Remove the temporary jumper between V+ and UIN.

Note: The temporary brake regulator jumper remains installed for the unintended motion test.

14. Unlock and turn ON the mainline disconnect.

15. Turn ON the CB1, I/O, and CPU Controller Switches.

16. Turn the Auto/Inspect Switch to Auto; The door switch should still be in the OFF position.

Unintended Motion Test

ASME A17.1 Section 2.19.2.2 requires the stopping unintended motion of car with 125% rated load DOWN, or empty car UP when the hoistway door is not in the locked position and the car door is not in the closed position. Perform the following test in Automatic Operation with the hoistway doors *simulated* unlocked, and the car door *simulated* opened.



WARNING

Do not perform the above test with the hoistway doors unlocked and the car doors opened. This test cannot be performed while the car is in Independent or Inspection Operation.

Note: The jumper between pins 1 and 2 on the brake regulator card (installed in the ascending car test) remains installed for the unintended motion test.

Unintended Motion Test - Part 1

1. Turn OFF the CPU, I/O, and CB1 Switches.
2. Turn OFF, Lock, and Tag out the mainline disconnect.



WARNING

Do not remove or add wires until the mainline disconnect is OFF and Locked Out. The safety circuit is 115vac, and electrical shock could occur if the safety circuit is live.

3. Remove the factory wire at the CS PMI Connector at PMI Card 1, connector 5 (P5), pin 5.
4. Strip both ends of a short temporary wire and install at the CS PMI Connector (in place of the removed factory wire).



WARNING

Jumper or wire ends must not contact any circuitry or conductive components. Electrical shock or controller damage could occur.

5. Connect a jumper, which can be easily removed, between the short wire installed at CS and the removed factory wire.
6. Remove the factory wire from GL input at PMI Card 1, connector P3, pin 11 and install a short temporary wire with both ends stripped.
7. Connect a jumper, which can be easily removed, between the removed GL PMI wire and the added wire.
8. Turn ON the mainline disconnect
9. Turn ON the CB1, I/O, and CPU Switches.
10. Place the car on Automatic operation with the door switch OFF.
11. Run the empty car to the bottom landing.

Unintended Motion Test - Part 2

1. Enter the TST5 Command. The Remote FAST displays “Run Unintended Motion Test? (Y/N).”
Note: The test will be aborted if the door switch is ON. The “Door disconnect required” will display.
2. Enter “Y” to enable the test. The Remote FAST displays “Enter car call to execute test.”
3. Enter a second landing car call.
4. After the car levels in to the floor and the car velocity in the Remote FAST is zero, immediately remove both the CS and GL Jumpers.
5. Use a non-conductive device to manually hold the BK1 and MC Contactor closed.

Notes:

- The machine brake will be held open during the sheave brake test as long as the BK1 and MC Contactors are closed.
 - When the car leaves the door zone, with the hoistway door simulated unlocked and the car door simulated open, the sheave brake should detect Unintended Motion and will drop the sheave brake. If the sheave brake does not drop, or the sheave brake drops but car movement does not stop within 48 inches, release the BK1 and MC Contactors to abort the test.
6. After the car has stopped during the test, type BTR in the Remote FAST (which displays the distance the car traveled in inches). BTR displays “Test Failed” if the car travel was greater than 48 inches.

Notes:

- Code requires that the car must stop within 48 inches or less.
 - If the test fails, check the spring adjustment and the shoe clearance.
7. Repeat the “Unintended Motion Test - Part 1” on page 34.
 8. Run the car to a landing where 125% rated load of test weights can be placed on the car.



WARNING

Prior to placing 125% rated load of test weights on the car, the machine brake must be adjusted.

9. After 125% capacity load is placed on the car, repeat the “Unintended Motion Test - Part 2”.
10. After all unintended motion tests have been performed successfully, turn the CPU, I/O, and CB1 Switches OFF and the Auto/Insp Switch to Insp.
11. Turn OFF, Lock, and Tag out the mainline disconnect.
12. Remove the temporary jumpers CS and GL and also the brake regulator jumpers. Reinstall the factory wires.
13. Turn ON the mainline disconnect.
14. With the door disconnect still OFF, turn the CB1, I/O, and CPU switches ON and the Auto/Insp Switch to Auto.
15. Place a car call to the landing where the test weights can be removed, and turn the door disconnect Switch ON.
16. Remove the test weights from the car.
17. Before placing the car into service, cycle the car to verify proper operation.

Ascending Overspeed Test TST7

CAUTION

The Ascending Overspeed Test (when enabled) will disable the ETSD electronic governor and the OSP overspeed protection. The car will NOT be prevented from decelerating. If the governor jaw or the Ascending Overspeed Device do not activate, the car will stop normally at the call floor. The system will automatically return to normal mode (all safety backup systems enabled) after completion of the test—with the exception of the governor switch and/or jaw.

Make certain that the following items have been done before proceeding with the Ascending Overspeed Test:

- All adjacent cars in the hoistway have been positioned at the bottom terminal floor and taken out of service.
 - The top of the car under test has been inspected and all objects have been removed.
 - The inside of the car under test has been inspected and all loose objects have been removed.
 - The 186C has been provided with V5R1H or later generic software.
 - The 2407MC has been provided with V2R27 or later drive software.
 - Prior to this test being performed, the Unintended Motion Test has been completed in the DOWN direction with 125% of rated load.
1. Disconnect the doors by setting D26 = 1 with the Remote FAST in IMS or by placing the door disconnect switch on the IOC card in the ON position.
 2. Turn OFF, Lock, and Tag out the mainline disconnect.
 3. Install a temporary jumper across terminals CON12, 107-108 on the IOC card to by-pass the governor overspeed switch.

WARNING

The Ascending Overspeed Brake Interface is to only be connected for the purpose of this test and is NOT to be left connected to the control system during normal operation.

4. Temporarily connect the Ascending Overspeed Brake Interface (AOBI), TKE part number 9735264, as follows. See Figure 23 on page 39.
 - a. Connect the FBK1 terminal CON1, Pin 1 of the AOBI to terminal 2 of fuse FBK1 (located on the PHRT terminal block on the controller).
 - b. Connect the FBK2 terminal CON1, Pin 5 of the AOBI to terminal 2 of fuse FBK2. If FBK2 is not provided, connect to AC2 (located on the PHRT terminal block on the controller).
 - c. Connect the GND terminal CON1, Pin 3 of the AOBI to the GND terminal on the PHRT terminal block in the controller.

Ascending Overspeed Test TST7

(continued)

- d. Connect the hoistway door lock monitor control for the AOBI to the controller.
 - For installations with front door operation, connect the HDL terminal CON1, Pin 2 of the AOBI to terminal 215 on the CVR1T terminal block in the controller.
 - For installations with rear door operation, connect the HDL terminal CON1, Pin 2 of the AOBI to terminal 225 on the CVR1T terminal block in the controller.
 - For installations with front and rear door operation, temporarily relocate the field wire on terminal 221 to terminal 215 on the CVR1T terminal block. Connect the HDL terminal CON1, Pin 2 of the AOBI to terminal 225 on the CVR1T terminal block in the controller.
 - e. Connect AC2 terminal CON1, Pin 4 of the AOBI to terminal AC2 on CHR1T terminal block in the controller.
 - f. Connect the normal brake coil leads to the AOBI as follows:
 - Temporarily remove the normal brake coil lead BRK++ and connect to BRAKE CON3, Pin 1 of the AOBI.
 - Temporarily remove the normal brake coil lead BRK-- and connect to BRAKE CON3, Pin 3 of the AOBI.
 - g. Connect the 2407BC Connector on the AOBI to the controller as follows:
 - Connect 2407BC CON2, Pin 1 of the AOBI to terminal BRK++ on PHR1T terminal block in the controller.
 - Connect 2407BC CON2, Pin 2 of the AOBI to terminal BRK-- on PHR1T terminal block in the controller.
 5. Turn ON the mainline disconnect.
 6. Verify that the controller is on Door Disconnect.
 7. Enter the TST7 = Overspeed, Accel. The Remote FAST displays "Register Terminal Car Call."
 - Over Speed = Ascending Overspeed Device activation point + 10 fpm.
 - 200 to 349 fpm activates at 125% of contract speed.
 - 350 fpm and above activates at 115% of contract speed.
 - Accel = desired acceleration rate from contract speed to trip speed.
- Note:** The overspeed acceleration rate must be less than or equal to the programmed acceleration value (M39).
8. Enter a top floor car call.
 9. As the car accelerates away from the floor, push and hold the "Push to Test" pushbutton on the AOBI.

Ascending Overspeed Test TST7

(continued)

10. After the car reaches top speed, increase the car speed by pressing and holding the UDL button.



WARNING

The Reset button is located next to the UDL button on the 186C card. If the reset button is pressed by accident, the drive and CPU will go off-line during a high-speed run.

Note: Release the UDL button to decelerate the car to contract speed.



WARNING

If the car does not decelerate to the rated buffer speed or the car keeps accelerating, abort the test; release the pushbutton on the AOBI to drop the normal brake.

11. Once the car has activated the Ascending Overspeed Device and has stopped the car, or the counterweights have struck the buffer(s) at or below the buffers rated speed, release the pushbutton on the AOBI.
12. Verify that the Ascending Overspeed Device activates at the proper car speed, that the car decelerates to the rated buffer speed, and that the car stops.

Note: The actual trip speed can be viewed by using the FLTN Command. Faults 1007 (Safety String Opened) and 1654 (Unintended Motion FLT) should display along with the car velocity and when the fault occurred.
13. Place the car controller on Inspection Operation.
14. Verify that no damage to the car or hoistway equipment has resulted from the test.
15. To reset the controller, enter RRF and TFR in the Remote FAST. Enter RFL to clear the faults.
16. Turn OFF, Lock, and Tag out the mainline disconnect.
17. If the Ascending Overspeed Device does not activate at the proper car speed, the car does not decelerate to the rated buffer speed, or the car does not stop, troubleshoot and repair all components. Repeat the Ascending Overspeed Test TST7.
18. Remove the temporary jumper from CON12 terminals 107-108.
19. Disconnect the AOBI that was connected earlier, and return the normal brake leads to terminals BRK++ and BRK- on PHR1T.
20. Reconnect the hoistway interlock wiring to the original configuration (if reconfigured for the test).
21. Reset the governor switch and/or jaws (if they have activated during the test).
22. Turn ON the mainline disconnect.
23. Verify operation of the car; cycle the car on Automatic Operation with the doors disconnected.
24. Turn the car doors ON (D26=0), or turn the Door Disconnect Switch on the IOC to the OFF position.
25. Place the car in service, or continue with other testing.

**Ascending
Overspeed Test
TST7**
(continued)

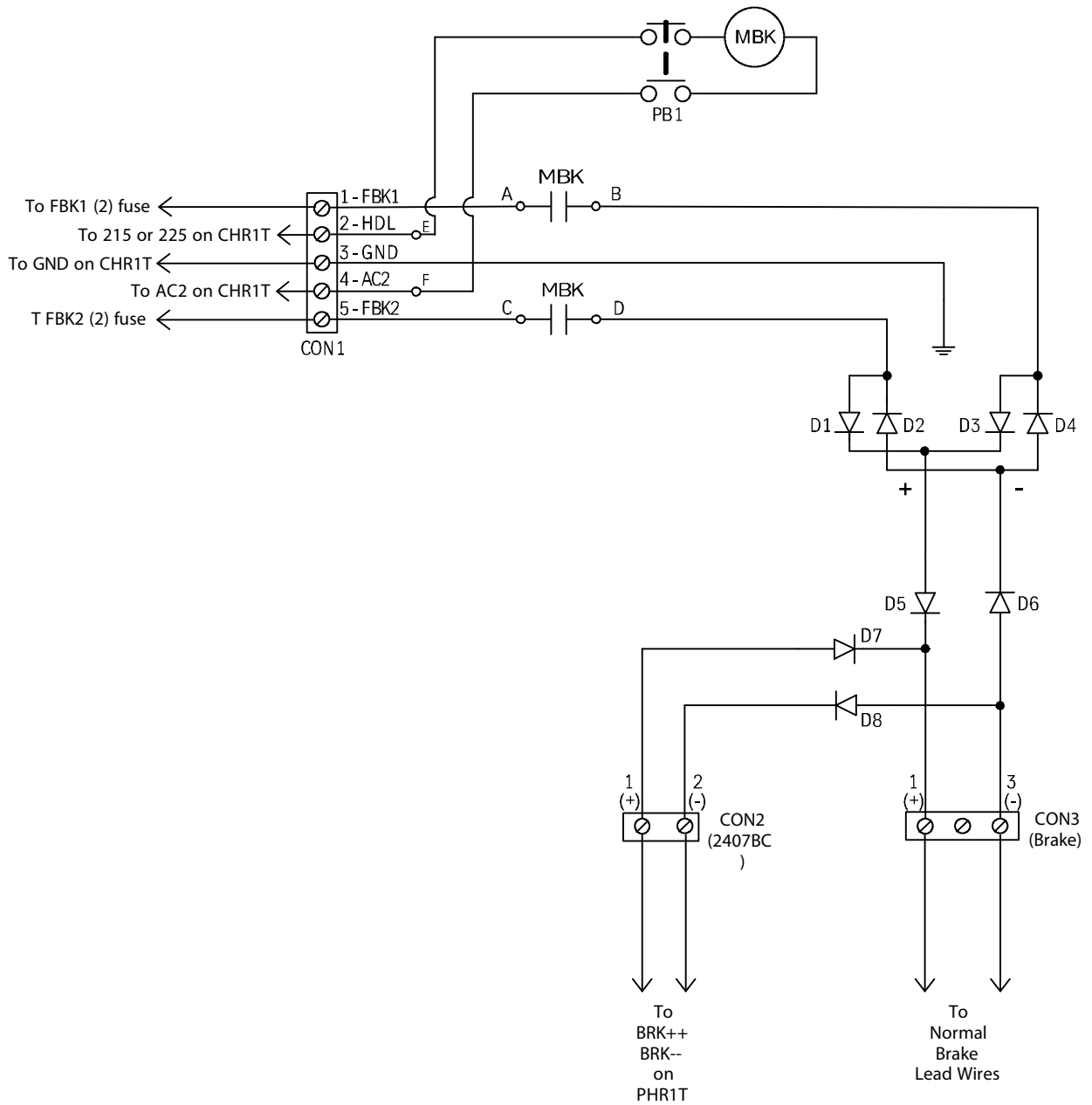
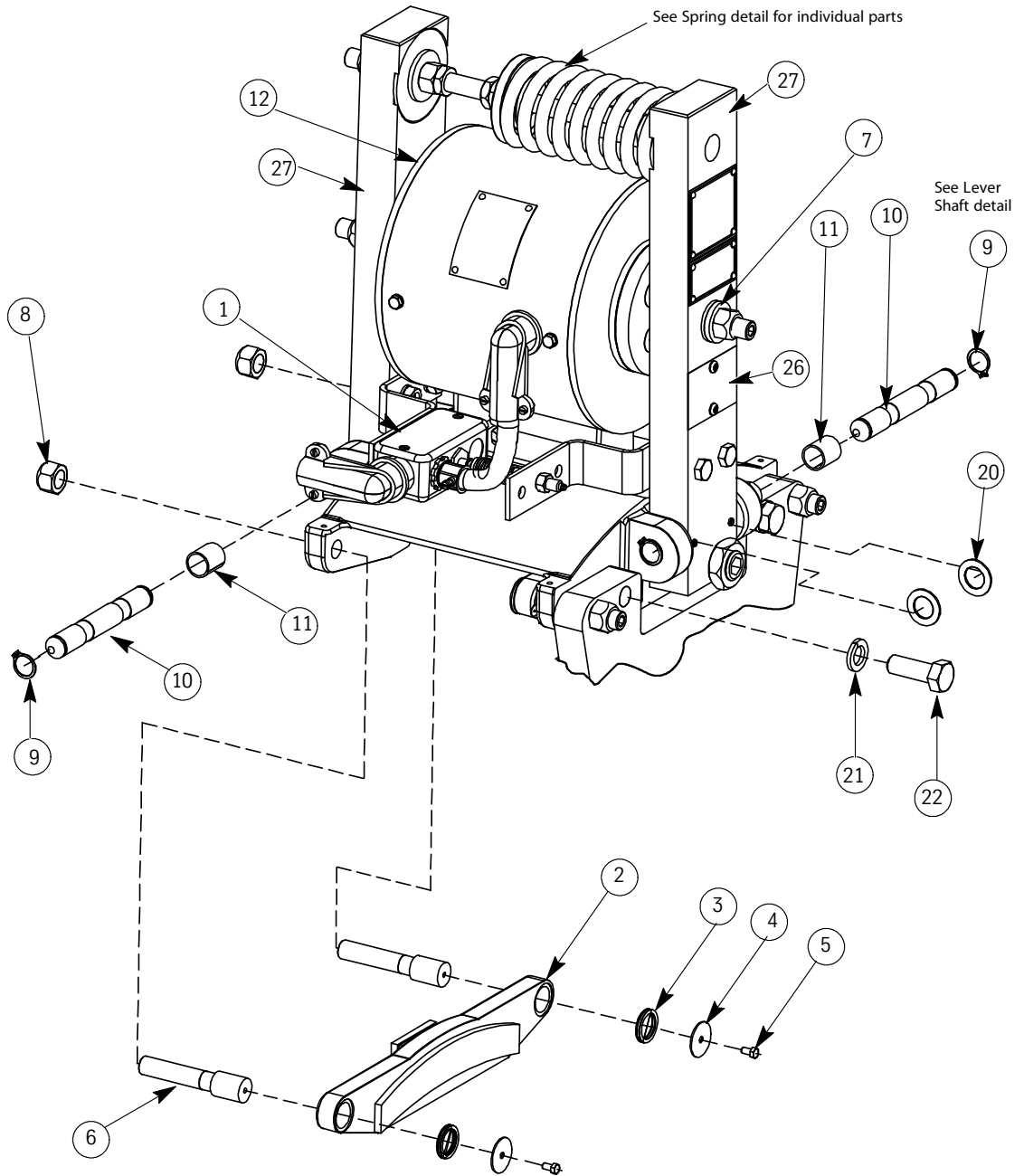

Figure 23 - Ascending Overspeed Brake Interface (AOBI)

Replacement Parts

205CT Sheave Brake Diagrams



**205CT Sheave
Brake, Lever Shaft
Detail**

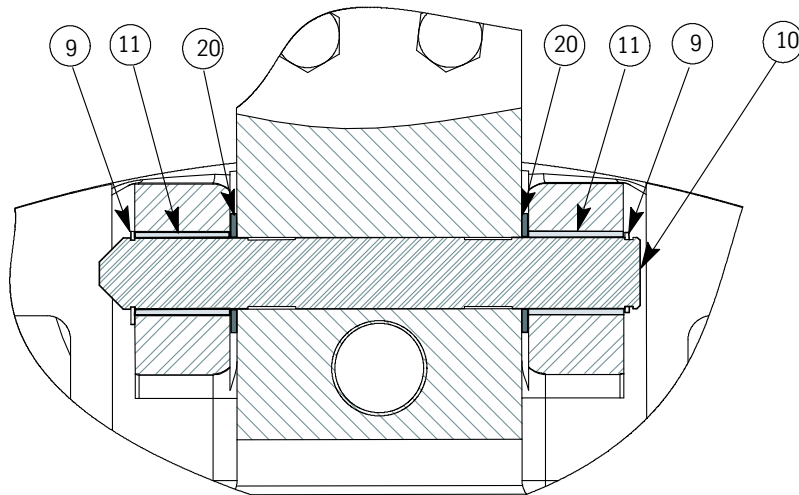

**205CT Sheave
Brake, Spring Detail**

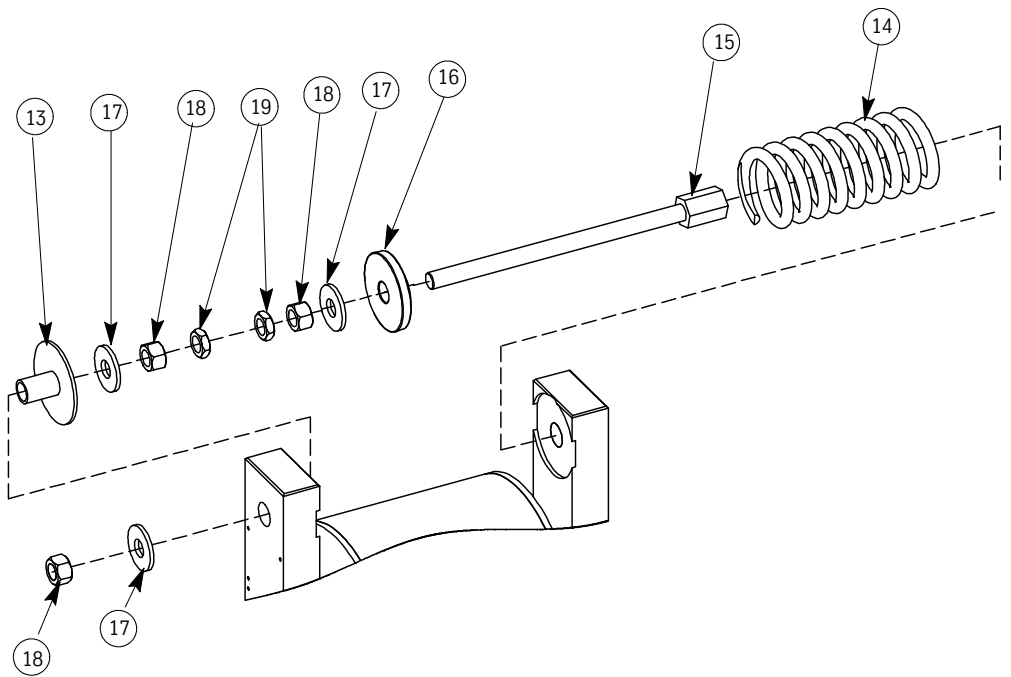

205CT Sheave Brake Parts List

ITEM	PART NO.	PRINT NO.	DESCRIPTION
1		171BA4	Brake Switch
2		596BW1	Brake Shoe Assembly
3		780CH1	Wave Spring
4		399CF1	Washer, Sheave Brake
5		405CW1	M5 x 10mm Cap Screw
6		454AH1	Guide Pin
7		408AN1	M16 Spherical Washer
8		402AF1	M16 Lock Nut
9		717AM2	3/4" Retainer Ring
10		744CN1	Lever Shaft
11		208BT1	Bushing
12		779AL1	Solenoid Assembly
13		208BN1	Nylon Bushing
14		780AR1	Spring
15		718CW1	Rod Weldment, Coupling
16		100014	Washer, Brake Spring
17		408AC5	Flat Washer M16
18		402AA3	Nut M16
19		402AB3	Jamb Nut M16
20		399CE1	Washer, Sheave Brake Arm
21		408AF1	Washer, Lock M16
22		405AL1	Screw, M16 x 45
23		760BR1	Shim, Sheave Brake (not shown)
24		760BR2	Shim, Sheave Brake Mounting Bracket (not shown)
25		200AEN1	Assembly, Help Kit (not shown)
26		165ACJ1	Plate, Feeler Gauge
27		558AC1	Lever, Actuating

779AL Sheave Brake Solenoid Assembly

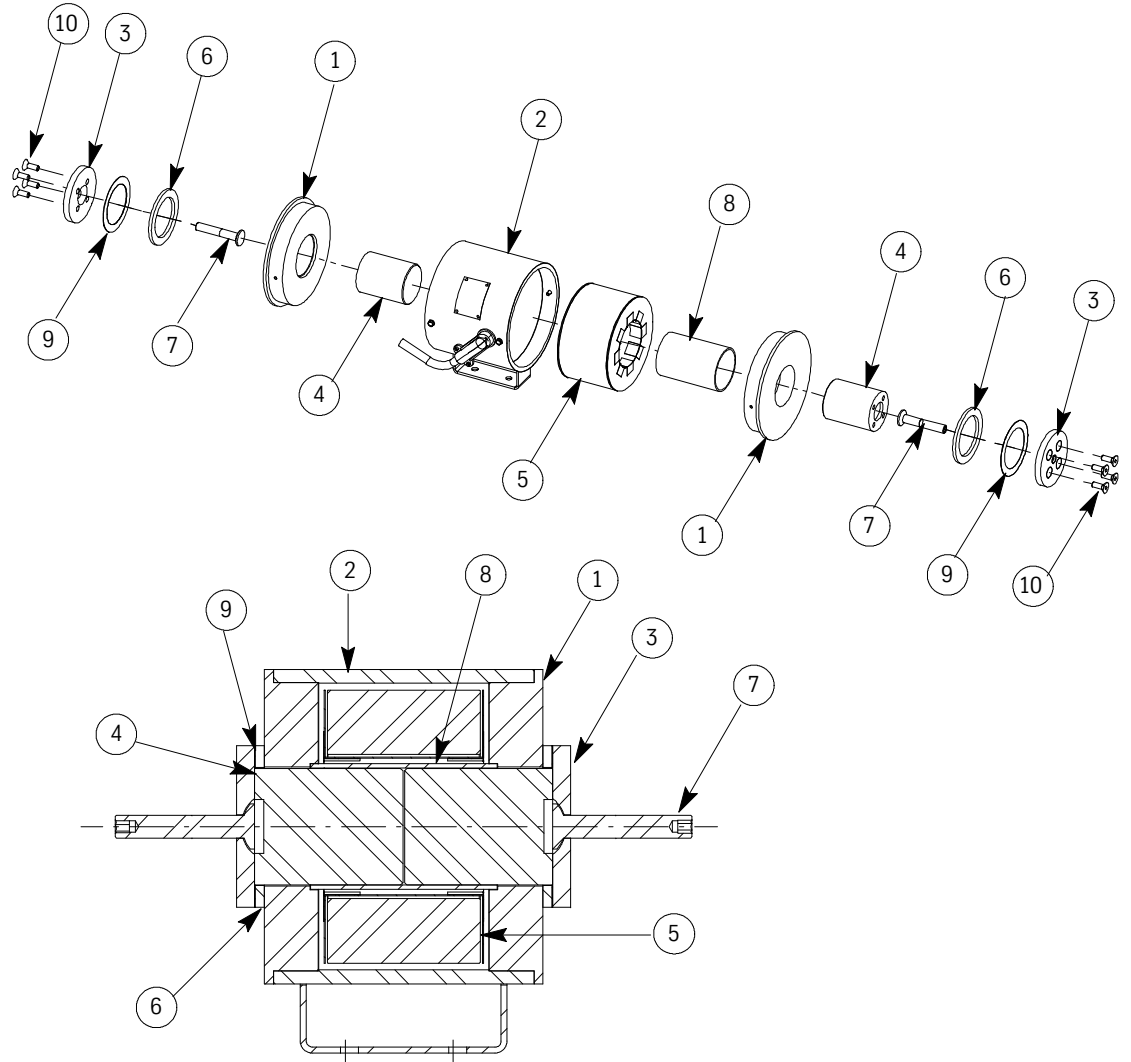

779AL Solenoid Assembly Parts List

ITEM	PART NO.	PRINT NO.	DESCRIPTION
1		165FC2	End Plate
2		482BF2	Housing
3		165FB2	Plate, Armature
4		181AF1	Armature
5		280BA1	Coil Assembly, 140 VDC
6		534BY1	Isolation
7		718BA1	Rod Pull
8		765AW1	Sleeve, 3.250 I.D.
9		760BL1	Shim
10		405CM1	FSM, Screw CSFHS M10 x 30 mm
11		71946	FS, Screw SDRU (not shown)
12		580WN1	Name Plate, Ascending Brake Coil (not shown)
13		77616	Conduit, Flexible (not shown)
14	9955367	77633	Conduit, Fitting 90 Degree Connector (not shown)
15		408AF5	FS Washer LWH High Collar Type M6 U (not shown)
16		405CJ1	FS, Screw M6 x 20mm U (not shown)

Vertical Express

P.O. Box 2019 Memphis, TN 38101 Tel: (866) 448-3789 (toll-free) Fax: (901) 261-1807 www.verticalxpress.com

All illustrations and specifications are based on information in effect at the time of publication approval. Vertical Express reserves the right to change specification or designs and to discontinue items without prior notification or obligation. v.Y.m. Copyright © 2012 Vertical Express Elevator