

TKE COMPONENTS TRACTION BUFFER SURVEY

JOB NAME:

JOB NUMBER:

Instructions:

1. If ordering buffers and buffer extensions only, provide values below for upper portion of survey only. Buffer channel values (bottom portion) required if ordering channels as well.
2. Provide following dimensions and values as required:

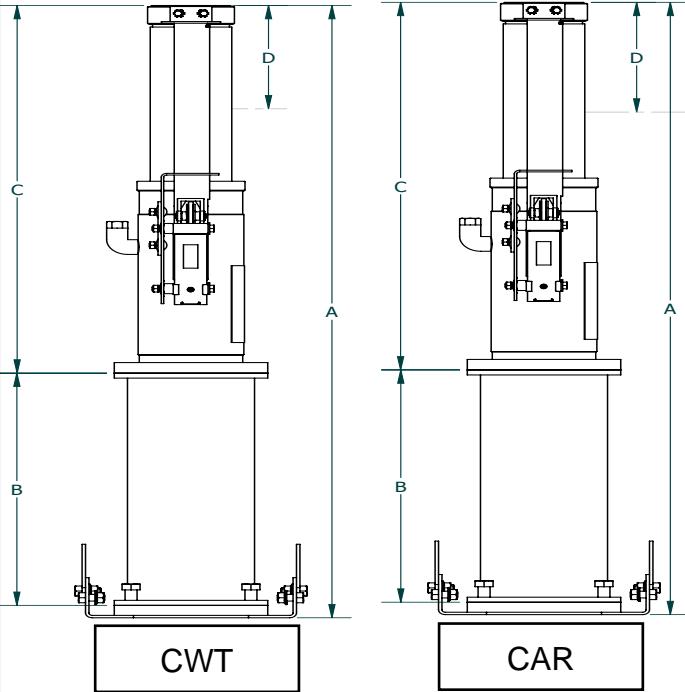

IF ORDERING BUFFERS & EXTENSIONS ONLY

	CAR	CWT
TOTAL QTY BUFFERS		
CAR SPEED		
BUFFER SWITCH REQUIRED (YES/NO)		
A: (PIT FLOOR TO TOP OF BUFFER)		
B: (BUFFER STAND HEIGHT)		
C: (BUFFER HEIGHT)		
D: (BUFFER STROKE)		

IF ORDERING BUFFER CHANNELS

	CAR	CWT
TOTAL QTY CHANNELS		
RAIL SIZE (8,15,18, 22#)		
C (DBG- DISTANCE BETWEEN FACE OF RAIL)		
D (FACE OF RAIL TO BUFFER CENTER)		
E (CENTER TO CENTER IF 2 BUFFER SETUP)		
F (FACE OF RAIL TO BUFFER CENTER)		

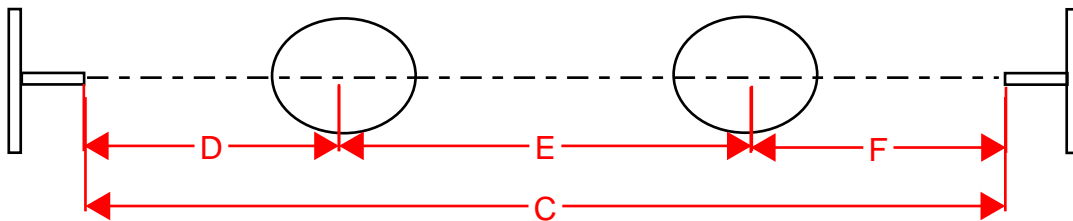

IF ONLY ONE BUFFER, SHOW "E" AS N/A